



AUSTRALIAN ARTISTIC COMMITTEE

FIGURE MANUAL

PRINTED AND COPYRIGHTED IN AUSTRALIA

This publication is sold subject to the condition that it shall not by way of trade or otherwise be lent, re-sold, hired out, copied or otherwise circulated, without SA prior consent in any form of binding or cover, other than that in which it is published and without a similar condition, including this condition being imposed on the subsequent purchaser.

11th Edition 2016

We thank the Roller Skating Rink Operators Association (America) for allowing us to reprint some of the contents of this manual.

TABLE OF CONTENTS

1	REGULATIONS FOR PROFICIENCY CERTIFICATE.....	1
1.1	REQUIREMENTS.....	1
2	REGULATIONS FOR PROFICIENCY TESTS.....	2
3	CORRECT CARRIAGE, FLOW AND MOTION IN COMPULSORY FIGURES.....	6
3.1	BASIC REGULATIONS.....	6
3.2	CARRIAGE.....	6
3.3	FLOW.....	6
3.4	MOTION.....	6
4	CORRECT TRACING.....	7
4.1	BASIC REGULATIONS.....	7
4.2	SPECIAL RULES FOR SPECIFIED FIGURES.....	8
5	FIGURE TESTS.....	10
5.1	GENERAL RULES:.....	10
6	LOOP FIGURE TEST.....	13
6.1	GENERAL RULES:.....	13
7	ROLLER SCHOOL FIGURES.....	21
8	SUMMARY.....	22
8.1	WHERE TO STAND AND WHAT TO LOOK FOR:.....	22
8.2	UNDERSTANDING IMPORTANT FIGURE TERMS.....	22
9	STARTING FIGURES.....	23
9.1	STANDING STARTS.....	23
9.2	TRANSITIONS.....	23
10	CONCLUDING FIGURES.....	24
11	TAKE-OFFS.....	24
11.1	IMPORTANT POINTS ON ALL TAKE-OFFS.....	29
12	CHANGE OF EDGE.....	30
12.1	COMMON FAULTS ON CHANGE OF EDGES.....	31
13	THREE TURNS.....	35
13.1	DRAWINGS OF PROBLEMS ON THREES.....	38
14	DOUBLE THREES.....	43
14.1	JUDGES OBSERVATIONS OF DOUBLE THREES.....	44
14.2	DRAWINGS OF COMMON ERRORS ON DOUBLE THREES.....	45
15	BRACKETS.....	50
15.1	IMPORTANT JUDGING TIPS ON BRACKETS.....	51
15.2	DRAWINGS OF BRACKETS.....	51
16	COUNTERS.....	55
16.1	IMPORTANT JUDGING TIPS ON COUNTERS.....	55
16.2	DRAWINGS OF COUNTERS.....	55
17	ROCKERS.....	58
17.1	IMPORTANT JUDGING TIPS ON ROCKERS.....	58
17.2	DRAWINGS OF ROCKERS.....	59
18	LOOPS.....	62
18.1	IMPORTANT JUDGING TIPS ON LOOPS.....	62
18.2	DRAWINGS OF LOOPS.....	63
19	MARKING FOR TESTS AND COMPETITIONS.....	68

1 REGULATIONS FOR PROFICIENCY CERTIFICATE

This test shall be optional and not considered as a prerequisite to the other tests in this handbook. Skaters wishing to commence proficiency tests at the first bar level of Dance, Free Dance, Figures Free Skating Singles or Free Skating Pairs may do so without having first taken a Proficiency Certificate Test.

Skaters shall prove their ability to skate forward and backward edges and execute a two-foot turn for the fee of \$1.00

This test shall be judged by one judge who must hold at least a the lowest level of commission available in any of the artistic fields. The candidate's performance will not be graded by scores; the judge will simply designate "PASS" or "FAIL".

1.1 Requirements

Commence from rest, unassisted by toe stops or barrier.

Skate forward edges.

Execute a two-foot turn (either a mohawk or choctaw)

Skate backward edges.

Come to a stop (either while backwards, or may turn forward and stop)

Note: The candidate should skate at least the length of the rink during the execution of the above requirements and should stop without engaging the barrier. A spread eagle turn is not acceptable. A clean two-foot turn executed with good weight transference from one foot to the other is required.

2 REGULATIONS FOR PROFICIENCY TESTS

1. One mark shall be awarded in accordance with the scale for each figure.
2. When marking figures, judges shall consider the following:-
 - (a) a good edge running, without flats or sub-curves
 - (b) superimposition
 - (c) clean turns, made in the correct position
 - (d) maintenance of a consistent speed throughout the figure
 - (e) style, carriage and movement.

It is not possible to assess exactly the penalty to be imposed for a given error as it depends very largely on the degree of the specific mistake. For example, the seriousness of a change of edge in a turn increases in direct proportion to the distance from the point of the cusp at which the change of edge occurs. Also a flat is of greater importance in direct relation to its length. The degree of an error is accentuated if it is repeated throughout the figure. A serious error is one, which is connected with the main feature of a figure (the actual turn, or loop or change of edge). A serious mistake also occurs when it follows immediately the execution of the main feature, as the mistake then indicates lack of control. Similarly, an error becomes more serious if it facilitates the execution of the main feature of the figure (ie. flats or change of edge before turns).

An accumulation or combination of various and different errors in a figure incurs a greater penalty than the single serious error alone. However, a single serious error, repeated throughout the figure, becomes worse than an accumulation of different errors.

3. The fact that a skater fails in a figure by a fall or putting down the non-tracing foot must not lead a judge to mark the figure as not skated. The following touchdown penalties shall apply:-
 - (i) If a skater falls or stops through his own fault in a figure, resulting in disruption of flow, the referee shall restart him at the point of failure just prior to the interruption. The distance shall be left to the referee's discretion, but shall be such that the skater is not further disadvantaged. Judges shall resume judging when the skater passes the point of the fall or the stop. The penalty for such a fault shall be one whole mark (1.0).
 - (ii) If a skater touches down due to loss of control, the penalty will be 1.0 on a major part of the figure and 0.5 on a minor part of the figure. A major part of the figure is a take-off, turn or change of edge. A minor part of the figure is the running edge connecting the major parts.
 - (iii) If a skater brushes a wheel on the floor in a manner which is hardly perceptible to the judges and the referee, there will be no set deduction by the Touchdown Rule. The fault will be penalised by the judges as appropriate in the assessment of the figure.
 - (iv) Where the skater performs an INCORRECT turn and a touchdown penalty as described in (i) and (ii) above is not involved. The Referee shall instruct the judges to reduce their score by one full mark (1.0) for each incorrect turn.
 - (v) Once a touchdown penalty has been imposed, the skater shall not be penalised again at the same point on the same tracing.
 - (vi) If a skater executes a take-off more than two skate-lengths from the junction of the long and the short axes, the referee shall stop the skater and have him complete the tracing from the point of take-off. This action should be taken

ONLY when it is obvious that the early take-off is due to lack of momentum, and not due to lack of judgement on the part of the skater to correctly place the take-off. Judges are directed by the referee to penalise an early take-off due to lack of momentum by one whole mark (1.0)

- (vii) The referee may allow the skater to start a figure a second time without penalty. However, a third strike-off will incur a penalty of one whole mark (1.0). The decision to restart is at the discretion of the skater but the decision must be made within the first One-third (1/3) of the initial circle.
 - (viii) The minimum mark which can be given for any figure is point one (0.1)
4. Figure skating is the skating of prescribed movements according to the schedule. For Australian Championships and proficiency tests, all figures (except Paragraph Figures but including paragraph loops), must be skated three (3) times without stopping after the initial start. Paragraph figures, except paragraph loops, must be skated two (2) times without stopping after the initial start.

All loops (including paragraph loops) must be skated three (3) times without stopping after the initial start.

5. Figures must be commenced from rest at the intersecting point of two circles. The only exception to this being Fig. 1a, 1b, 2a and 2b which may be commenced on the long axis at the end of a set of circles.

Starts must be made with a single push from a stationary position without lunging, buckling or double leans. The starting edge should be a pure edge without flats or sub-curves. No impetus may be taken from the foot, which is about to become the tracing foot, ie. double tracking is not permitted. Every stroke should be taken from the four wheels and not the toe-stop.

6. The Referee shall signal the start and finish of each figure with one (1) whistle blast on each occasion. When two tests are being run simultaneously, a verbal command shall be given to start and finish.
7. The Referee shall inform the candidate, which figure is to be skated and shall see that the candidate starts the figure into the correct circle and on the correct foot and edge.
8. Any skater making an appeal to the Referee for a second strike-off after fouling in the first third of the first circle may have such re-start without penalty. A third strike-off will incur an automatic penalty of 1.0.
9. If the skater is interfered with in any way which causes him to fall or stop, the Referee shall allow the skater to start the figure anew. The referee instructs the skater to skate the figure anew. Judging re-starts from the point of interruption. No penalty is involved. The referee may allow whatever period of rest he Referee deems necessary.

10. EARLY TAKE-OFF - Due to lack of momentum

A take-off of more than two (2) skate lengths before the junction of the long and short axis is not to be judged as an early take-off. This is a failure to complete the circle and the Referee shall stop the skater and re-start him, at the point of failure, on the correct edge and foot for the completion of the circle. The skater is to finish the circle and commence the next take-off at the junction of the long and short axis.

The Referee shall advise the judges that a major penalty is involved and he shall direct them to reduce their mark accordingly (one whole mark reduction, 1.0).

Below is a diagram illustrating the correct take-off and an early take-off for a ROF to a LOF edge: -

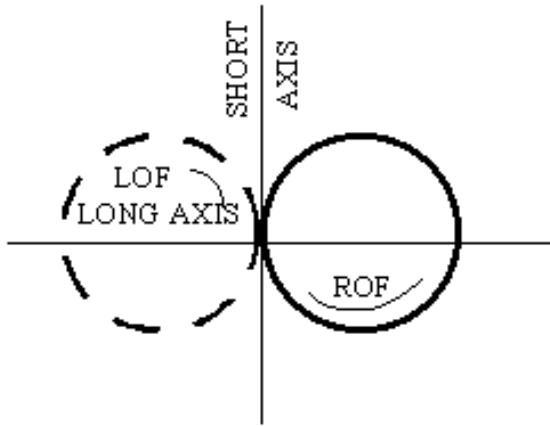

CORRECT TAKE-OFF

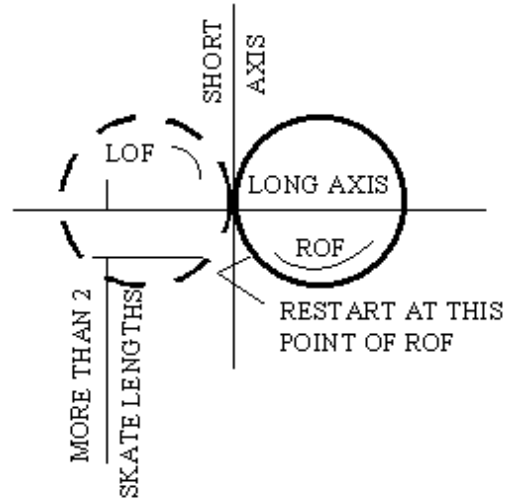

EARLY TAKE-OFF

11. REQUEST FOR REPEAT OF FIGURE

Once all figures in a proficiency test have been completed a judge may, if a performance was unsatisfactory, ask for one or more figures to be re-skated.

The illustrations below show the tracings at the take-offs.

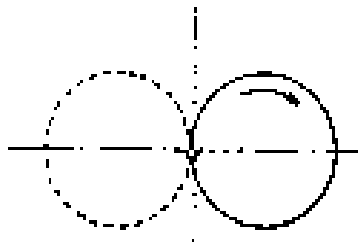

CIRCLE EIGHT
Fig.1 ROF - LOF

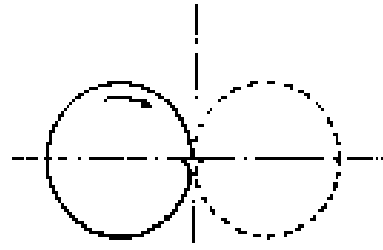

CIRCLE EIGHT
Fig.3 ROB - LOB

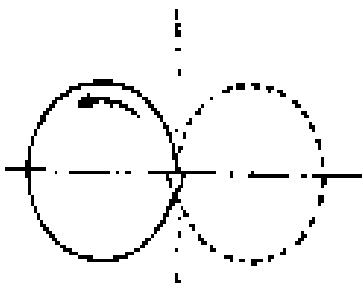

CIRCLE EIGHT
Fig.2 RIF - LIF

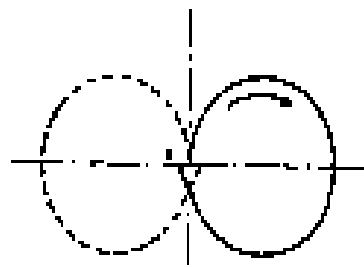

CIRCLE EIGHT
Fig.4 RIB - LIB

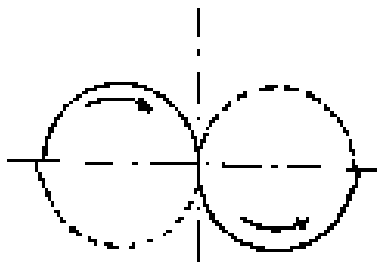

CHANGE EIGHT
Fig.1a ROIF - LOIF
Fig.1b LOIF - ROIF

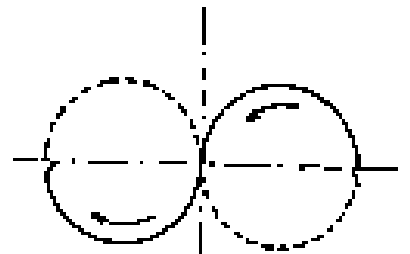

CHANGE EIGHT
Fig.2a RIOF - LIOF
Fig.2b LIOF - RIOF

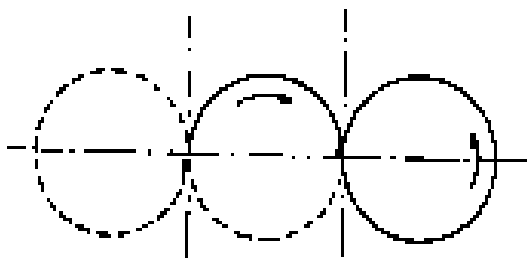

SERPENTINE
Fig.5a ROIF - LIOF
Fig.6b LOIB - RIOB

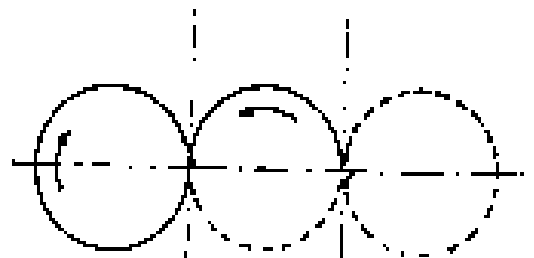

SERPENTINE
Fig.5b LOIF - RIOF
Fig.6a ROIB - LIOB

3 CORRECT CARRIAGE, FLOW AND MOTION IN COMPULSORY FIGURES

3.1 BASIC REGULATIONS

- (a) Above all, an effortless, flowing and graceful execution should be achieved
- (b) Within the limits of the following rules, freedom is granted to the individuality of the skater.

3.2 CARRIAGE

For correct carriage the following directions are to be observed:

- (a) The head should be carried in an upright position, relaxed and held naturally.
- (b) The body should be upright but not stiff and not bent forward or to the side at the hips.
- (c) The arms should be held gracefully, without raising the hands or the elbows far away from the body.
- (d) The hands should not be carried higher than the waist, the palms held easily, naturally and parallel to the floor.
- (e) The fingers should neither be extended nor clenched.
- (f) The skating leg should not be stiff but should be flexible with the knee slightly bent.
- (g) The free leg should be very slightly bent at the knee, generally held over the tracing, with the free foot not too close to the skating foot. When the leg is in front, its knee and ankle are to be gracefully extended.
- (h) The free foot is to be carried slightly above the floor, the toe of the skate pointing downward and outward.
- (i) Exaggerated positions should be avoided.

3.3 FLOW

A consistent speed, rhythm and even flow should be maintained throughout, avoiding jerky, abrupt and angular movements.

3.4 MOTION

Moderate use of the arms and free foot to assist the execution of the compulsory figure is permitted within the range of the foregoing paragraphs.

There are certain tricks used by skaters in an effort to assist the execution of their figures. Judges should be aware of these, in order to recognise when a skater is cheating.

CROSS PULLING is a primary source of momentum in which the free leg or some other portion of the body is moved across or at an angle to the tracing, causing the tracing foot to follow.

STEERING occurs when the tracing skate does not follow the arc to be skated, and the skater continually pulls the leading wheels of the skate back to the line.

FORCED EDGES are tracings made with the weight outside the circumference of the curve and with the ankle dropped - usually associated with a double lean.

LUNGING occurs during take-offs. The skater throws the body forward from the hips up, in an effort to gain momentum.

HITCHED TAKE-OFF is an incorrect movement of the employed skate, which involves skidding or jumping forward of the heel wheels in order to assist forward take-offs.

4 CORRECT TRACING

4.1 BASIC REGULATIONS

- (a) Circles; long and short axis.

The circle is the fundamental of all school figures. Each school figure consists of two circles or three circles, which join each other except for a brief interruption to their continuous tracing due to a change of feet. The circles and half circles should begin and end as near as possible to the intersection of the long and short axis.

The long axis of the figure divides it longitudinally into symmetrical halves. The short axis divides the figure into symmetrical circles. It forms a right angle with the long axis where the circles join. Figures, which consist of three circles, have two short axes, which divide the figure into three equal circles.

- (b) Curves; (parts of circles).

Curves should be skated with a clean edge, uninterrupted tracing, without wobbles or sub-curves inward or outward.

- (c) Changes of edge.

All changes of edge should be made at the intersection of the long and short axis, with a smooth, even transition. A good change of edge will produce a flat approximately the length of the employed foot. There is no prescribed action of the free leg.

Common errors: double leans, flats, "S" curves, sub-curves and pulls.

- (d) Turns.

The turns are to be skated with a clean edge up to the turn, and similarly after the turn, without skids, or scrapes, made quietly and without obvious lifting of the wheels, and not hooked or pulled, or unpermitted changes of edge either before or after the turn. The cusps of the turns should be of equal size. The entry into and the exit from the turns should be symmetrical. In turning a forward outside Three, International style, the free leg and foot are carried slightly behind and in line with the skating foot, and the free foot being turned downwards and outwards.

4.2 SPECIAL RULES FOR SPECIFIED FIGURES

(a) Loops.

Loops should be clean cut, without skids or scrapes and of an even speed. The entry - exit crossing of the loop tracing, as well as the centre of the head of the loop itself, should lie on the long axis of the figure and divides the loop into symmetrical halves.

Common errors: circles instead of loops, uneven shoulders, off axis, buckling, double leans, pulling out too soon or too late, rocking action at head of loop.

(b) Three Turns.

A one foot turn from a forward edge to the opposite backward edge or vice versa with the direction of the turn being the same as the initial edge (ie. the cusp inside the circle). The turn should be placed on the long axis, with the second curve the same size as the first. The depth of the cusp of the turn is approximately one skate length, and the shoulders of the turn should be even. The turns should be executed with a smooth even rotation, not jumped or pulled.

Common errors: double leans, buckling, and flats before and after, off axis, sub-curves, kicked, jumped and pulled turns.

(c) Double Three.

Two consecutive Three Turns on the same foot and the same arc. The first turn is executed at a point 1/3 of the way around the circle; the second curve shall cut the long axis at right angles, and the second turn is executed at a point 2/3 of the way around the circle. The cusps of the turns shall point to the centre of the circle being skated and the three curves shall be of equal size.

Common errors: misplacement of turns and errors listed for Three Turns.

(d) Brackets.

One foot turns from a forward edge to the opposite backward edge or vice versa, with the rotation of the turn being contrary to the initial edge (ie. the cusp outside the circle). The turn should be placed on the long axis and the depth of cusp should not exceed one half the length of the skate. There should be no change of edge before or after the turn. There is no prescribed free leg action.

Common errors: flats or changes of edge before or after the turns, double leans, off axis, jumped turns, cutting off the circle, pulled turns.

(e) Rocker Turns.

A one-foot turn from a forward edge to a similar backward edge or vice versa, with the rotation of the turn being the same as the initial edge. They should be turned without change of edge and the turns should be placed on the long axis, with the cusp not exceeding one half the length of the skate. There is no prescribed free leg action.

Common errors: double leans, changes of edge before or after the turns, flats before and after the turns, pulled turns, buckling and off axis.

(f) Counter Turns.

A one-foot turn from a forward edge to a similar backward edge or vice versa, with the rotation of the turn being contrary to the direction of the initial edge. They should be turned on the long axis, with a cusp not exceeding one half the length of the skate and without a change of edge before or after the turn. There is no prescribed action for the free leg.

Common errors: double leans, buckling, off axis, pulled turns, flats before or after turns, jumped turns, changes of edge.

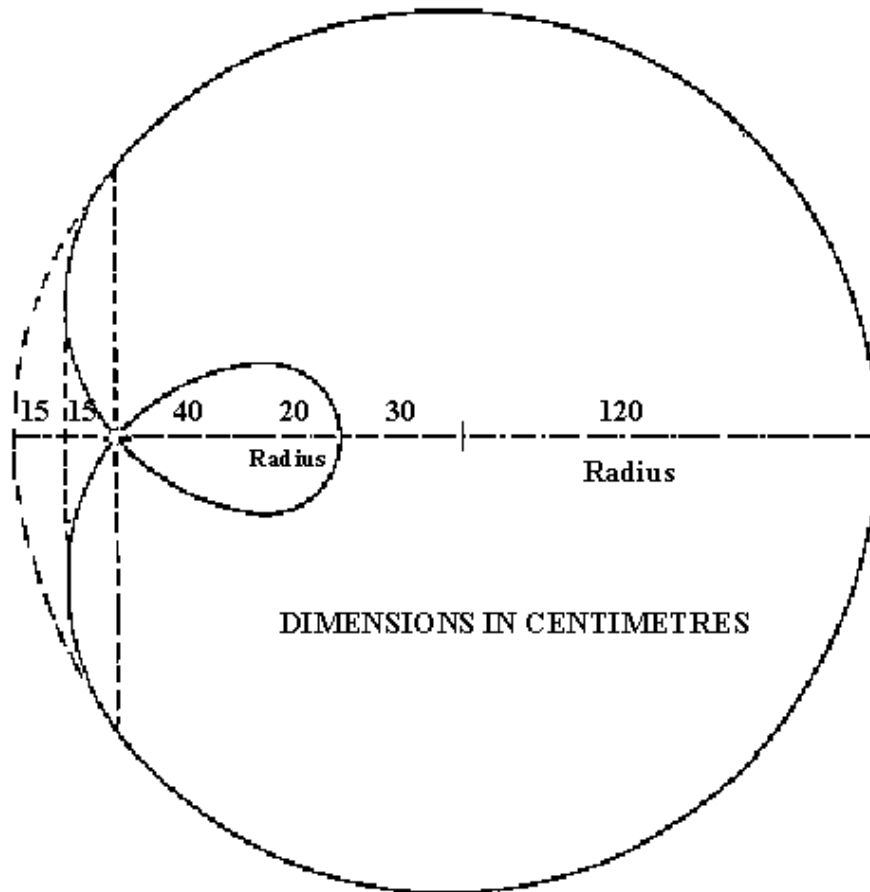

5 FIGURE TESTS

5.1 GENERAL RULES:

To pass a figure test, the candidate must receive a minimum mark of 5 for each figure and at least the minimum passing total mark from a majority of the judges.

FIGURE TESTS

No. 1 TEST (Award - 1st Bronze Bar)

All of the 3 judges must hold at least a Bronze Figure commission. The referee must hold at least a Bronze Figure commission or a referees' commission. If no referee is available then the highest qualified judge will referee the test.

No. 2 TEST (Award - 2nd Bronze Bar)

As for No. 1 Test

No. 3 TEST (Award - 3rd Bronze Bar)

As for No. 1 Test

No. 4 TEST (Award - 4th Bronze Bar)

As or No. 1 Test

No. 5 TEST (Award – Bronze Medal)

As for No. 1 Test

No. 6 TEST (Award - 1st Silver Bar)

Judges must hold at least a Silver Figure Commission

No. 7 TEST (Award - 2nd Silver Bar)

As for No. 6 Test

No. 8 TEST (Award - 3rd Silver Bar)

As for No. 6 Test

REQUIREMENTS

Minimum Passing Total: 11

1. 1 ROF - LOF Circle Eight
2. 1b LOIF - ROIF Change Eight

Minimum Passing Total: 12

1. 2 RIF - LIF Circle Eight
2. 2b LIOF - RIOF Change Eight

Minimum Passing Total: 12

1. 5a ROIF - LIOF Serpentine
2. 5b LOIF - RIOF Serpentine

Minimum Passing Total: 12

1. 3 ROB - LOB Circle Eight
2. 7 ROF - LOF Three

Minimum Passing Total: 13

1. 9a RIF - LOB Three
2. 9b LIF - ROB Three

Minimum Passing Total: 21

1. 8a ROF - LIB Three
2. 8b LOF - RIB Three
3. 11 RIF - LIF Double Three

Minimum Passing Total: 21

1. 10 ROF - LOF Double Three
2. 26a ROIF - LOIB Serpentine Three
3. 26b LOIF - ROIB Serpentine Three

Minimum Passing Total: 35

1. 12 ROB - LOB Double Three
2. 24a ROIF - LIOF Paragraph Eight
3. 24b LOIF - RIOF Paragraph Eight
4. 28a ROIF - LIOF Serp. Double Three
5. 28b LOIF - RIOF Serp. Double Three

FIGURE TESTS

No. 9 TEST (Award – 4th Silver Bar)

As for No. 6 Test

No. 10 TEST (Award – Silver Medal)

Judges must hold at least a Silver Figure Commission and one should be from an outside Club.

No. 11 TEST (Award – 1st Gold Bar)

Judges must hold at least a Gold Figure Commission and one should be from an outside club.

No. 12 TEST (Award – 2nd Gold Bar)

As for No. 11 Test

No. 13 TEST (Award – 3rd Gold Bar)

As for No. 11 Test

No. 14 TEST (Award – 4th Gold Bar)

As for No. 11 Test

REQUIREMENTS

Minimum Passing Total : 42

1. 19a RIF - LOB Bracket
2. 19b LIF - ROB Bracket
3. 22a ROF – LOB Counter
4. 22b LOF – ROB Counter
5. 27a RIOF – LIOB Serpentine Three
6. 27b LIOF – RIOB Serpentine Three

Minimum Passing Total: 49

1. 4 RIB – LIB Circle Eight
2. 6a ROIB – LIOB Serpentine
3. 6b LOIB – RIOB Serpentine
4. 20a ROF – LOB Rocker
5. 20b LOF – ROB Rocker
6. 23a RIF - LIB Counter
7. 23b LIF - RIB Counter

Minimum Passing Total: 52.5

1. 13 RIB - LIB Double Three
2. 14 ROF – LOF Loop
3. 15 RIF - LIF Loop
4. 18a ROF – LIB Bracket
5. 18b LOF – RIB Bracket
6. 21a RIF - LIB Rocker
7. 21b LIF - RIB Rocker

Minimum Passing Total: 52.5

1. 16 ROB – LOB Loop
2. 29a ROIB – LIOB Serp. Double Three
3. 29b LOIB – RIOB Serp. Double Three
4. 30a ROIF – LIOF Serpentine Loop
5. 30b LOIF – RIOF Serpentine Loop
6. 32a ROIF – LOIB Serpentine Bracket
7. 32b LOIF – ROIB Serpentine Bracket

Minimum Passing Total: 52.5

1. 17 RIB - LIB Loop
2. 31a ROIB – LIOB Serpentine Loop
3. 31b LOIB – RIOB Serpentine Loop
4. 33a RIOF – LIOB Serpentine Bracket
5. 33b LIOF – RIOB Serpentine Bracket
6. 34a ROF – LIF Paragraph Three
7. 34b LOF – RIF Paragraph Three

Minimum Passing Total: 60

1. 35a ROB – LIB Paragraph Three
2. 35b LOB – RIB Paragraph Three
3. 36a ROF – LIF Para. Double Three
4. 36b LOF – RIF Para. Double Three
5. 38a ROF – LIF Paragraph Loop
6. 38b LOF – RIF Paragraph Loop
7. 40a ROF – LIF Paragraph Bracket
8. 40b LOF – RIF Paragraph Bracket

FIGURE TESTS

No. 15 TEST (Award - Gold Medal)

As for No. 11 Test

REQUIREMENTS

Minimum Passing Total: 60

1. 25a ROIB - LIOB Paragraph Eight
2. 25b LOIB - RIOB Paragraph Eight
3. 37a ROB - LIB Para Double Three
4. 37b LOB - RIB Para Double Three
5. 39a ROB - LIB Paragraph Loop
6. 39b LOB - RIB Paragraph Loop
7. 41a ROB - LIB Paragraph Bracket
8. 41b LOB - RIB Paragraph Bracket

6 LOOP FIGURE TEST

6.1 GENERAL RULES:

To pass a loop figure test, the candidate must receive a minimum mark of 5.0 for each figure and at least the minimum passing total from a majority of the judges

LOOP TESTS

REQUIREMENTS

No. 1 LOOP TEST (Award - Bronze Bar)

Minimum Passing Total: 13

At least one of the three judges must hold at least a Bronze Figure Commission. The other two judges may hold a No. 1 Figure Commission

1. 14 ROF - LOF Loop
2. 15 RIF - LIF Loop

No. 2 LOOP TEST (Award - Silver Bar)

Minimum Passing Total: 14

All three judges must hold at least a Silver Figure commission

1. 30a ROIF - LIOF Serpentine Loop
2. 30b LOIF - RIOF Serpentine Loop

No. 3 LOOP TEST (Award - Silver Bar)

Minimum Passing Total: 14

As for No. 2 Test

1. 16 ROB - LOB Loop
2. 17 RIB - LIB Loop

No 4 LOOP TEST (Award - Gold Bar)

Minimum Passing Total: 15

All three judges must hold at least a Gold Figure commission

1. 31a ROIB - LIOB Serpentine Loop
2. 31b LOIB - RIOB Serpentine Loop

No. 5 LOOP TEST (Award - Gold Bar)

Minimum Passing Total: 30

As for No. 4 Test

1. 38a ROF - LIF Paragraph Loop
2. 38b LOF - RIF Paragraph Loop
3. 39a ROB - LIB Paragraph Loop
4. 39b LOB - RIB Paragraph Loop

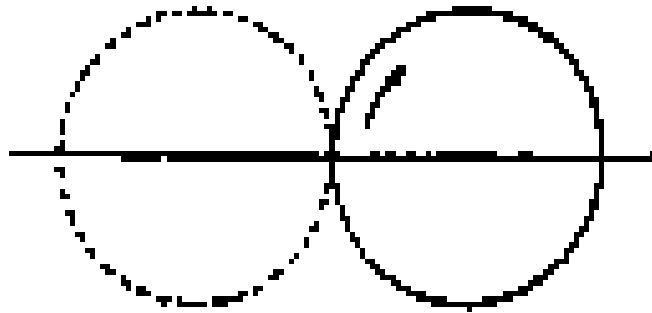

CIRCLE EIGHT

Fig 1	ROF - LOF
" 2	RIF - LIF
" 3	ROB - LOB
" 4	RIB - LIB

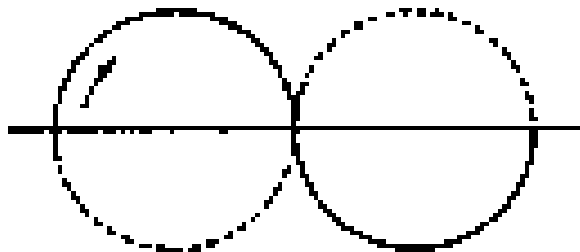

CHANGE EIGHT

Fig. 1a	ROIF - LOIF
" 1b	LOIF - ROIF
" 2a	RIOF - LIOF
" 2b	LIOF - RIOF

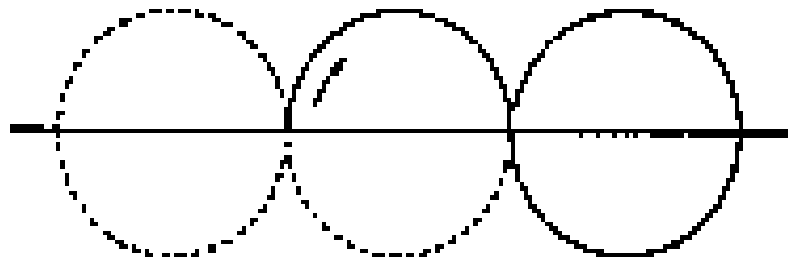

SERPENTINE

Fig. 5a	ROIF - LIOF
" 5b	LOIF - RIOF
" 6a	ROIB - LIOB
" 6b	LOIB - RIOB

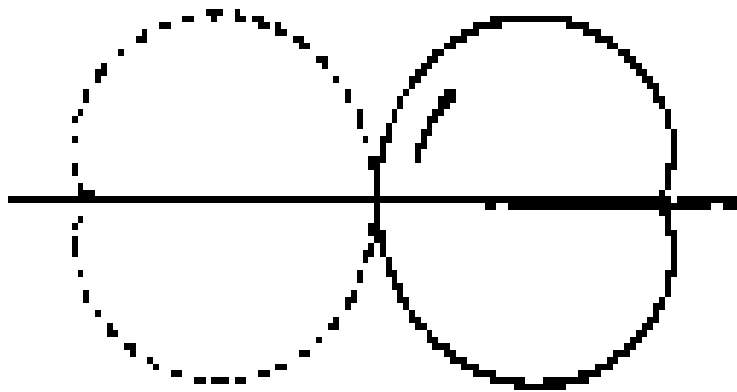

" 8a	ROF	-	LIB
" 8b	LOF	-	RIB
" 9a	RIF	-	LOB
" 9b	LIF	-	ROB

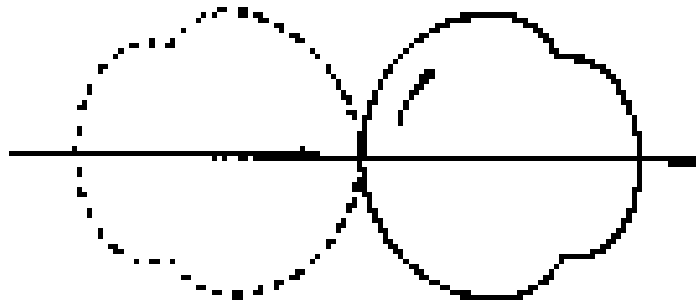

DOUBLE THREE

Fig. 10	ROF	-	LOF
" 11	RIF	-	LIF
" 12	ROB	-	LOB
" 13	RIB	-	LIB

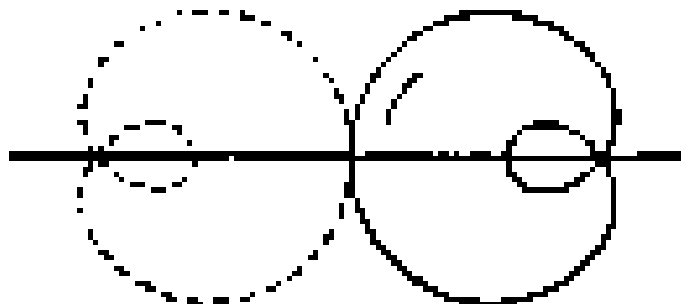

LOOP

Fig. 14	ROF	-	LOF
" 15	RIF	-	LIF
" 16	ROB	-	LOB
" 17	RIB	-	LIB

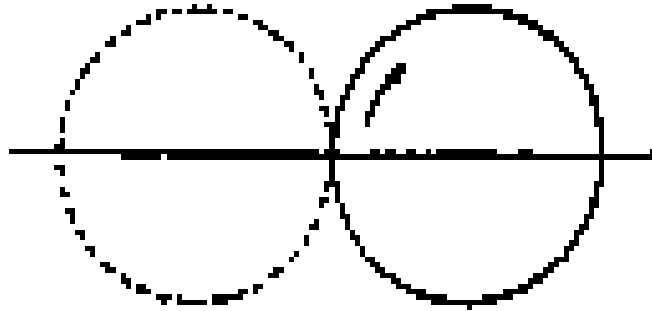

BRACKET

Fig. 18a	ROF	-	LIB
" 18b	LOF	-	RIB
" 19a	RIF	-	LOB
" 19b	LIF	-	ROB

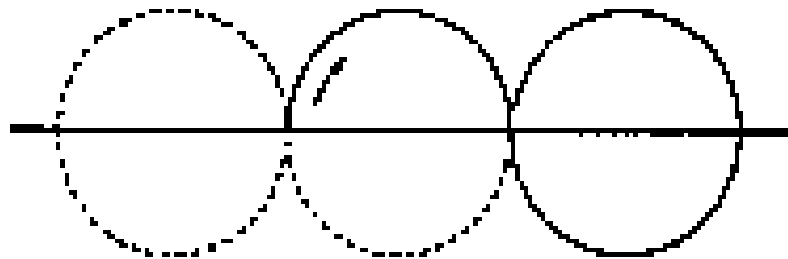

ROCKER

Fig. 20a	ROF	-	LOB
" 20b	LOF	-	ROB
" 21a	RIF	-	LIB
" 21b	LIF	-	RIB

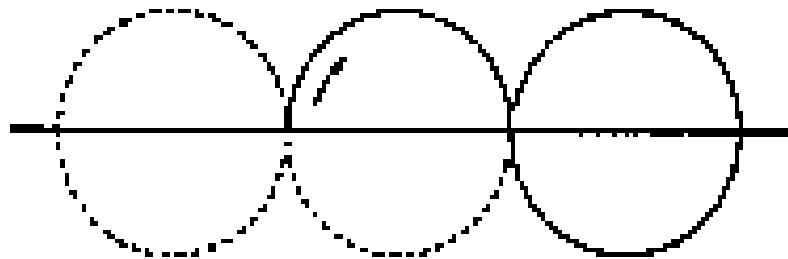

COUNTER

Fig. 22a	ROF	-	LOB
" 22b	LOF	-	ROB
" 23a	RIF	-	LIB
" 23b	LIF	-	RIB

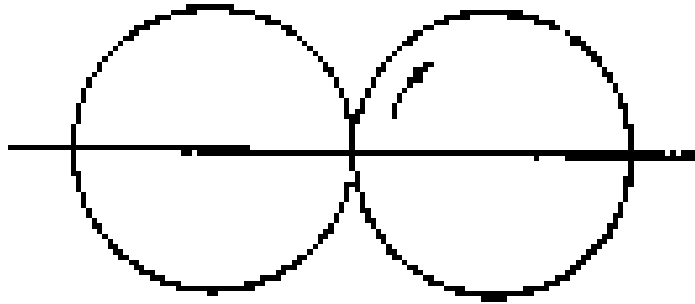

PARAGRAPH EIGHT
(One-foot eight)

Fig. 24a	ROIF -	LIOF
" 24b	LOIF -	RIOF
" 25a	ROIB -	LIOB
" 25b	LOIB -	RIOB

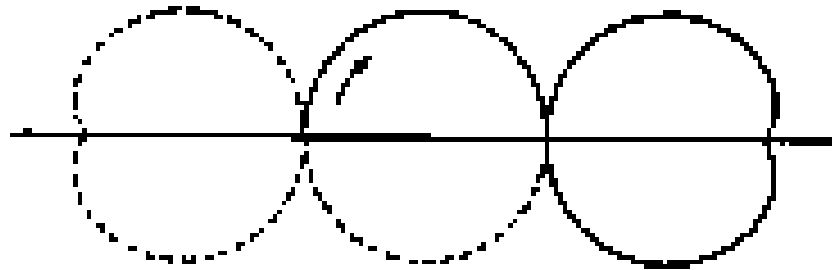

SERPENTINE THREE

Fig. 26a	ROIF -	LOIB
" 26b	LOIF -	ROIB
" 27a	RIOF -	LIOB
" 27b	LIOF -	RIOB

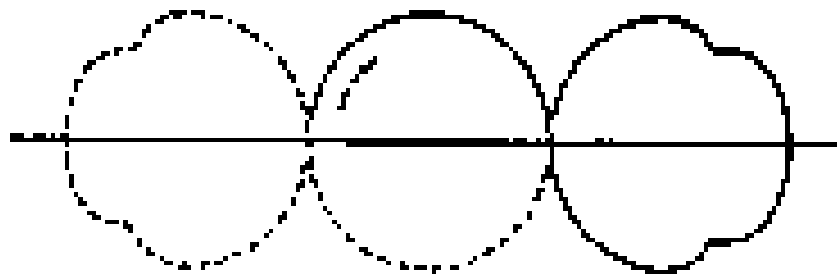

SERPENTINE DOUBLE THREE

Fig. 28a	ROIF -	LIOF
" 28b	LOIF -	RIOF
" 29a	ROIB -	LIOB
" 29b	LOIB -	RIOB

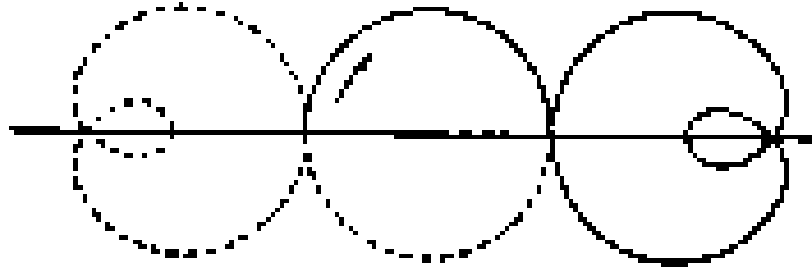

SERPENTINE LOOP

Fig. 30a	ROIF -	LIOF
" 30b	LOIF -	RIOF
" 31a	ROIB -	LIOB
" 31b	LOIB -	RIOB

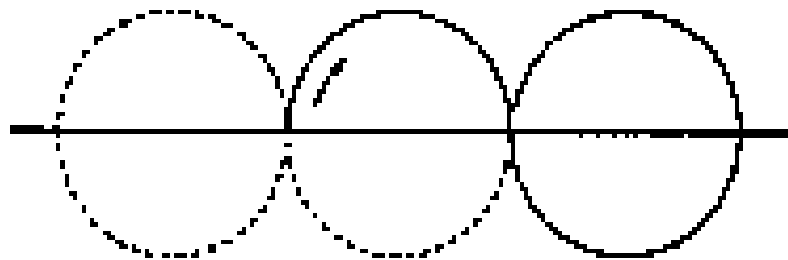

SERPENTINE BRACKET

Fig. 32a	ROIF -	LOIB
" 32b	LOIF -	ROIB
" 33a	RIOF -	LIOB
" 33b	LIOF -	RIOB

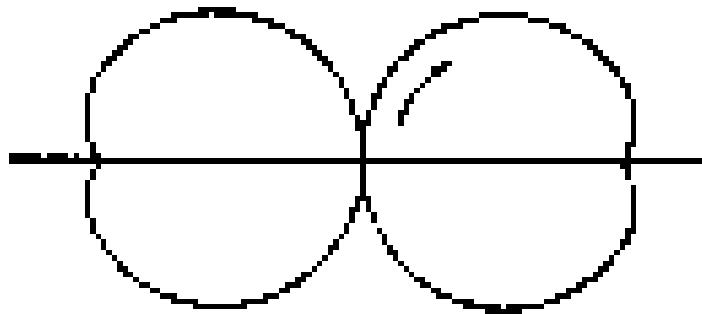

PARAGRAPH THREE

Fig. 34a	ROF -	LIF
" 34b	LOF -	RIF
" 35a	ROB -	LIB
" 35b	LOB -	RIB

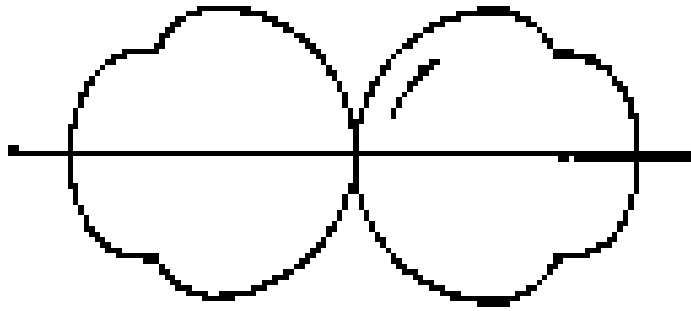

PARAGRAPH DOUBLE THREE

Fig. 36a	ROF - LIF
" 36b	LOF - RIF
" 37a	ROB - LIB
" 37b	LOB - RIB

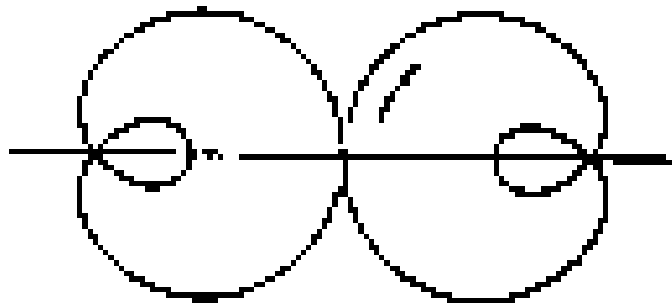

PARAGRAPH LOOP

Fig. 38a	ROF - LIF
" 38b	LOF - RIF
" 39a	ROB - LIB
" 39b	LOB - RIB

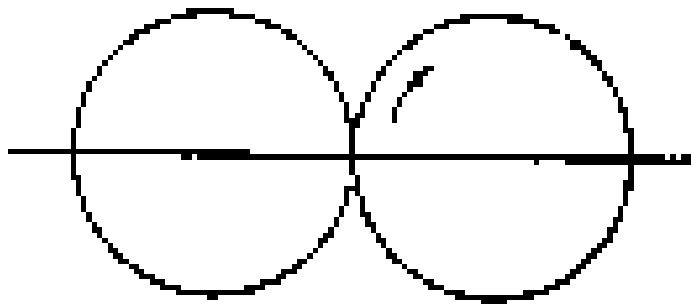

PARAGRAPH BRACKET

Fig. 40a	ROF - LIF
" 40b	LOF - RIF
" 41a	ROB - LIB
" 41b	LOB - RIB

The following pages have been included in the figure manual to promote and improve figure skating in Australia.

Some slight changes have been made in wording (eg. Marking) to adapt the information to conditions prevailing in Australia.

We thank the Roller Skating Rink Operators Association (America) for allowing us to reprint contents of their own various manuals and for their continuing efforts to improve, promote and upgrade roller skating throughout the world.

7 Roller School Figures

By Ron Jellse, SRSTA, Bedford Park, IL

The judging of Roller School Figures is a much more difficult task than judging other forms of Art Skating. A Figure Skating Judge must judge a figure while it is happening. He must be quick to observe both the good and bad points of the figure, since there is nothing to observe after completion. We all know there are certain portions of each figure that are the most difficult, thus the judge should be most careful to see the execution of the most difficult portions, since such portions are most likely to show the differences between competitors, or between failing or passing a test.

The Judge, in his concern to position himself to view the more difficult portions of the figure, should not overlook the importance of viewing the full performance of the figure. He should not, for example, take a position at the extreme end of a three circle figure, such as a Change Bracket, and particularly sacrifice his opportunity to view the skating of the whole figure merely to get a closer view of one difficult turn.

Where a judge stands is very important in figures. It depends upon the figure and also the individual perspective of each judge. In general, for two circle figures, a position at the side will give a good perspective of the whole figure, as well as a near enough view of the turns at either end. For three circle figures, it is usually best to stand opposite the centre circle, but near one of the changes leading into one or the other of the end circles. If a judge feels that a backward change or a backward turn is the most difficult portion of the figure, a stand by the centre circle near such a change or turn will place the judge in the best position to view it. In other words, a judge should plan before he judges, deciding which feature he must be careful not to miss. He should then move to the position he considers most advantageous.

Judges should move with the skater to get the best view of what they want to see, but at the same time must stand at a reasonable distance so they do not interfere with the skater or the other judges.

8 SUMMARY

8.1 WHERE TO STAND AND WHAT TO LOOK FOR:

- I. A judge should know the difficult parts of each figure and plan ahead to place himself in a position to see them.
- II. A judge should watch and evaluate the entire figures, keeping in mind that the difficult parts fit together into his score which is for the whole figure.
- III. Judges should move with the skater to observe the whole figure, but must not interfere with either the skater or the other judges.

8.2 UNDERSTANDING IMPORTANT FIGURE TERMS

Style - The individual manner of execution of the skater on a figure.

Correct Tracing - Keeping the skate as closely as possible to the painted line of the figure, with no deviation from the arc being skated. The tracing shall be a pure edge with no flats or sub-curves.

Correct Carriage – See page 6

Edge Quality - The degree of purity or excellence of the edge. The degree of absence of flats or sub-curves.

Pace - The rate of movement of the skate around the figure.

Rhythm - The regular pattern of body movement around the figure.

Double Repetition - The correct repetition of School Figure twice through.

Triple Repetition - The correct repetition of a School Figure three times through.

STYLE should not be a determining factor in the passing of a test or in the outcome of a figure contest. The judge in figure skating should assign a mark on the basis of a correct tracing (which includes double or triple repetitions), and carriage and movement, as defined under Judging Points on School Figures.

The meaning of CORRECT TRACING can easily be misunderstood. The terms defined earlier all have a part in CORRECT TRACING.

First, let us take the terms in reverse order. DOUBLE and TRIPLE REPETITION refer to the **consistency** of doing the figure well. In Roller Figure Skating a judge has to recognise the good and bad points done in the first repetition and watch to see if these are repeated in the following repetitions. His mark is on the ability of the skater to hit the “bull’s eye” each repetition, and how perfectly the figure is done each time through.

Second, RHYTHM, PACE and EDGE QUALITY are factors in CORRECT TRACING. The body RHYTHM of the skater has a bearing on his rate of movement around the figure and the excellence of his edge.

Different skaters have different rates of RHYTHM and PACE around the circles. Just because a skater has a difference PACE on the circle, or a different body RHYTHM than the judge is used to seeing in his local club, he should be able to evaluate this difference approach in its own right. A figure skater that is fast is not necessarily steady, or a slow figure skater is not necessarily a controlled figure skater.

The Judge, to evaluate CORRECT TRACING, can ask three questions:

1. How correct was each repetition during the skater's, either, DOUBLE or TRIPLE REPETITIONS?
2. Was the PACE and RHYTHM around the circle even throughout the entire figure?
3. What was the degree of EDGE QUALITY throughout the entire figure?

9 Starting Figures

9.1 Standing Starts

- A. The standing start must be made with a single push from a stationary position; without lunging, buckling and double leans.
- B. The starting edge should be a **pure edge** without flats or sub-curves.
- C. The start must be made from the "flat of the to-be-unemployed foot only. Starts made from toe stop must be penalised by the judges.
- D. The thrusting or pushing foot to be placed no more than one skate length from the long axis.
- E. The thrusting foot cannot move toward the long axis, until the striking foot moves into the direction of the required initial edge.
- F. The thrusting foot must leave the floor before crossing the long axis.
- G. The pace of standing and moving take-offs should be as similar as possible.

9.2 Transitions (Take-offs)

Transition - A change from one edge to another; a change from one circle to another; a take-off.

Transitions, or starts, are divided into two parts:

- A. The "thrust" either from rest or from the foot upon which the previous circle has just been skated.
- B. The "strike" upon and by the new skating foot.

10 Concluding Figures

It is to be accepted as equally correct in concluding a figure to use a subsequent take-off, or the method of continuing the roll past the long axis, without a subsequent take-off.

11 Take-offs

Long Axis - An imaginary straight line which passes through the centres of the two or three circles.

Short Axis - An imaginary straight line that vertically crosses the long axis at the point of tangency of the circles, sometimes called the “transverse” axis.

Strike Zone - A zone of approximately one skate length on either side of the long axis where the skater changes feet and transfers his weight from one foot to the other.

Diagram:

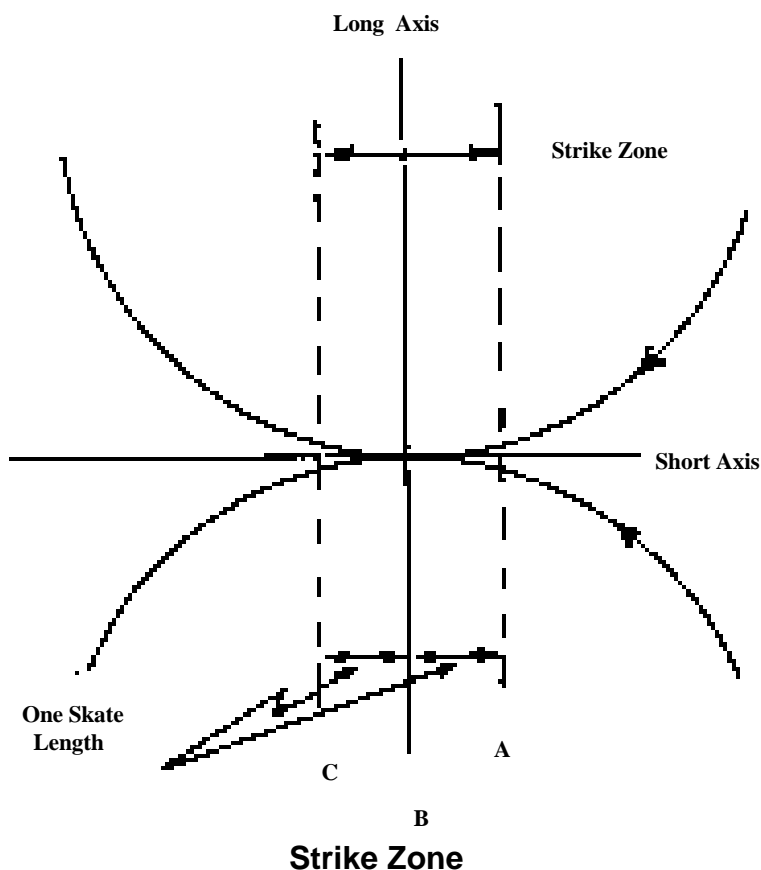

For the incoming or outgoing edge, the skater must go at least as far as point “A” on his employed foot, at which time he will slide the employed foot and push onto a new edge at the same time. When stepping onto the new edge, he must place it between points “B” and “C”. This is the allowable skate length distance in which a skater must place his skate on a take-off. This holds true for all take-offs, although the skater will take more of the allowable skate length on backward take-offs. Outside take-offs will have a tendency to be late. Inside take-offs will have a tendency to be early.

Diagram:

Outside forward Take-off

OF Take-off Example No. 1

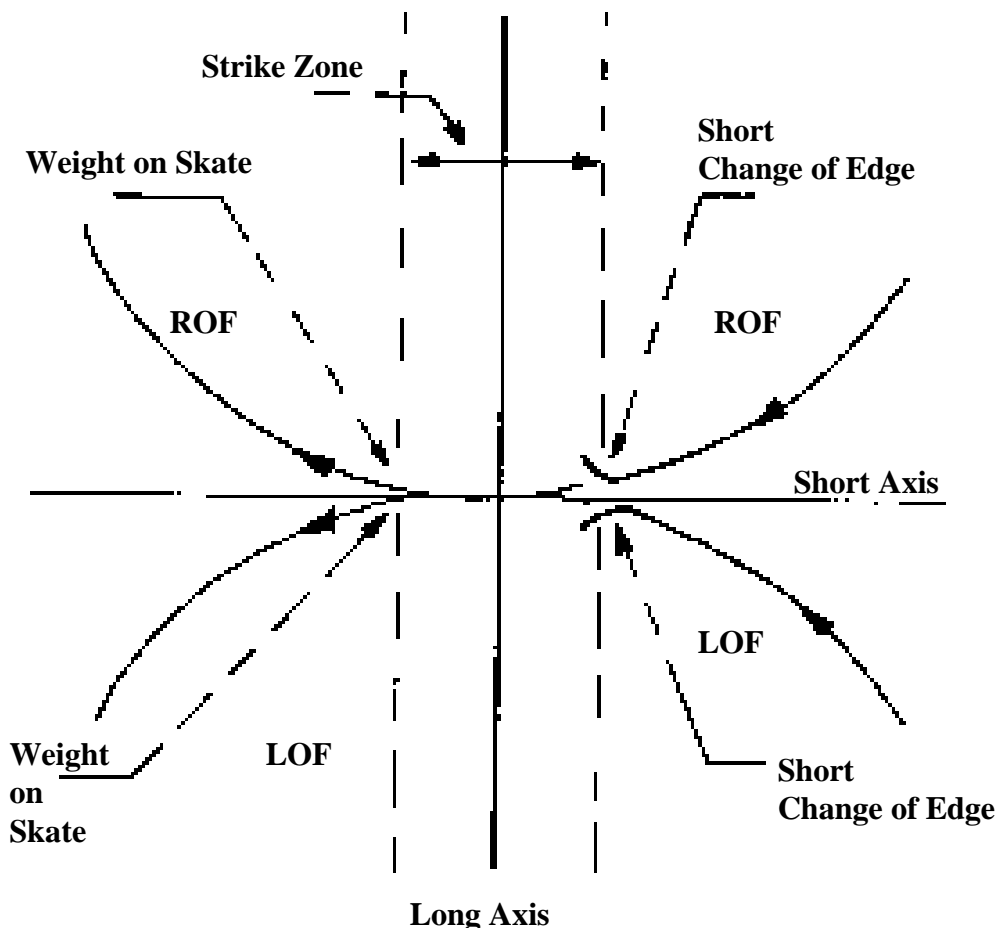

1. The outside forward edge is maintained right up to the strike zone (approximately one skate length from the long axis). A sharp, but true, outside forward curve of departure from the main circle is followed immediately by a short quick change of edge to the inside from which the thrust is made.
2. Any part of the striking skate may take the floor at the axis.
3. The thrusting foot pivots, stops and leaves the floor before crossing the long axis.
4. The skate stops, but the forward motion continues.
5. The take-off should be a quick precise transition from one foot to the other with a single push from the skate leaving the surface.
6. The feet should be reasonably close during the take-off.

Diagram:

Inside Forward Take-off

IF Take-off Example No. 2

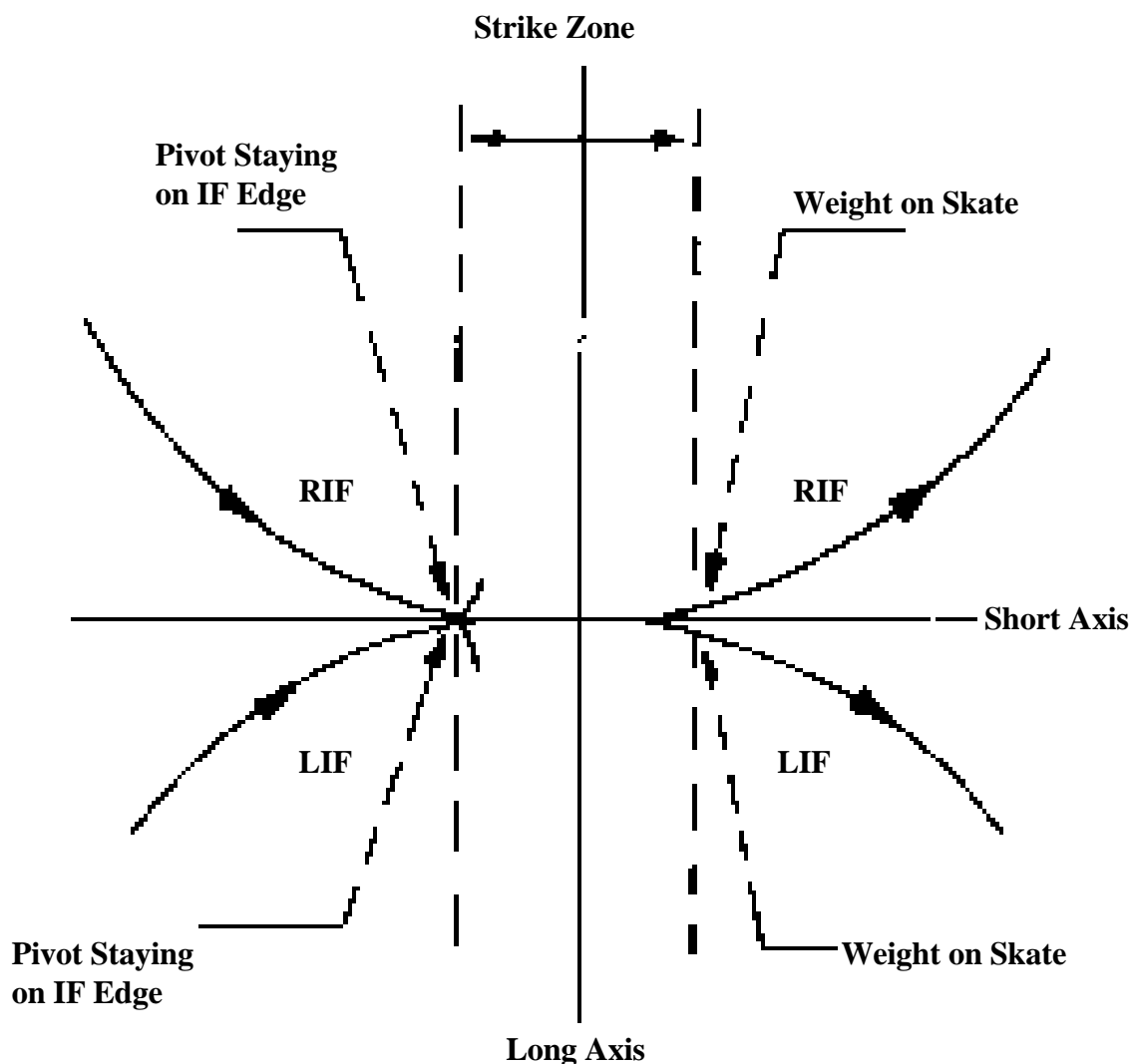

1. The inside forward edge is maintained right up to the strike zone, (approximately one skate length from the long axis) followed immediately by a quick pivot staying on the inside edge from which the thrust to the new inside edge is made.
2. The inside forward take-off is different from the outside take-off in that there is no short rockover on the take-off. This take-off must be done inner to inner.
3. The inside forward take-off is much harder to close to the strike zone than the OF take-off.
4. Any part of the striking skate must take the floor at the axis.
5. The take-off should be a quick precise transition from one foot to the other with a single push from the skate leaving the surface.
6. The feet should be close during the take-off.

Diagram:

Outside Back Take-off

OB Take-off Example No. 3

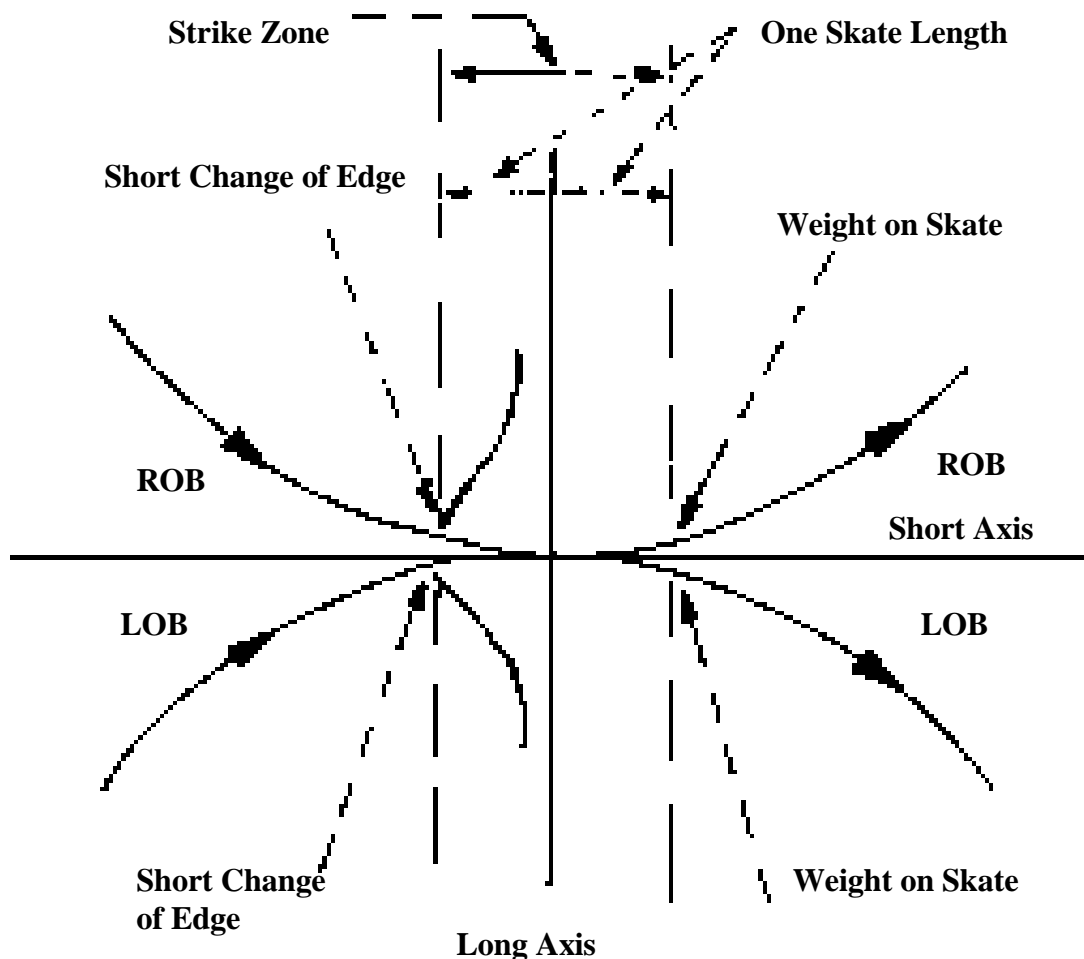

1. The outside backward edge is maintained right up to the strike zone (approximately one skate length from the long axis). A sharp but true outside back curve is made for the departure from the main circle, followed immediately by a short quick change of edge to the inside from which the thrust is made.
2. Any part of the striking skate may take the floor at the axis.
3. The thrust foot pivots, stops and leaves the floor before crossing the long axis. NOTE: Backward take-offs are difficult to stop before touching the long axis. It is not considered an error to touch the long axis as long as you do not keep both feet on the floor and drag the thrusting foot through.
4. The thrusting foot should not recross the circle previously traced.
5. The skate stops, but the motion continues.
6. The take-off should be a quick precise transition from one foot to the other with a single push from the skate leaving the surface.
7. The feet should be reasonably close during the take-off.

Diagram:

Inside Back Take-off

IB Take-off Example No. 4

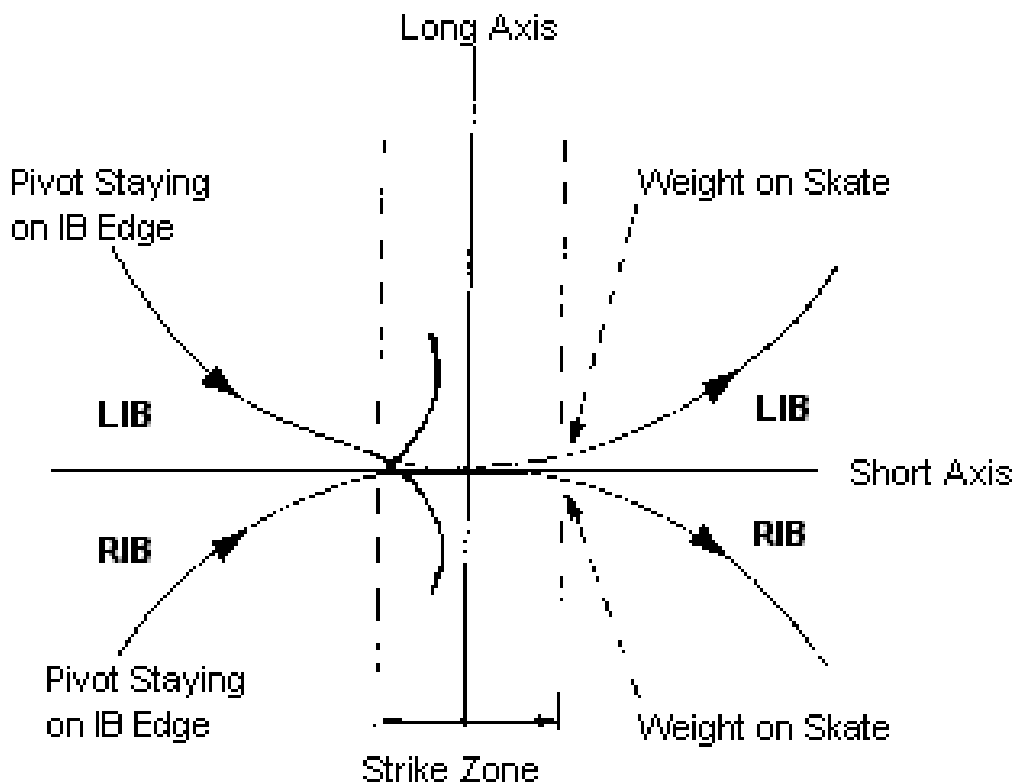

1. The inside backward edge is maintained right up to the strike zone (approximately one skate length from the long axis) followed immediately by a quick pivot staying on the inside edge from which the thrust to the new inside edge is made.
2. The inside backward take-off is different from the outside take-off in that there is no short rockover on the take-off. The take-off must be done inner to inner.
3. The inside backward take-off is much harder to close to the strike zone than the OB take-off.
4. Any part of the striking skate must take the floor at the axis.
5. The thrusting foot pivots, stops and leaves the floor before crossing the long axis. NOTE: Backward take-offs are difficult to stop before touching the long axis. It is not considered an error to touch the long axis as long as you do not keep both feet on the floor and drag the thrusting foot through.

11.1 Important Points on all Take-offs

1. The edges on all take-offs should be held to one skate length before the axis and the new employed foot should assume the weight of the body no later than one skate length past the long axis (the strike zone on all take-offs).
2. The pushing skate should leave the floor before rolling through the long axis.
 - The outer take-offs have a tendency to be late.
 - The inner take-offs have a tendency to be early.
 - The slide on the inner take-offs must be done from the inside of the foot (inner to inner).
 - The backward take-offs are more difficult to stop before touching the long axis. The skate may touch the long axis as long as both feet are not left on the floor and the pushing foot dragged through. The pushing foot may not recross the circle previously traced.
3. Only one thrust in a figure is made from rest, and this should be made with good edge quality (absence of flats or sub-curves). The other thrusts occur when the skater has momentum and may differ slightly from the original thrust from rest. However, this difference should be avoided if possible.
4. Take-offs should be quick, precise changes from one foot to the other with a single push from the skate leaving the surface.

NOTE: This is not to be construed that the take-offs are to be done violently. Everything violent, stiff or angular is to be avoided.
5. All take-offs are skated with complete control over the skate at all times. This means that an even roll or flow is preferred on take-offs to skate a figure of consistent edge quality.

NOTE: The pace of the take-offs once chosen should not move with a jerky forward-backward motion.

12 Change of Edge

Change of Edge (Abr. C-E) - A change of curve from outside to inside, or vice versa, on one foot without a change of direction of the skate.

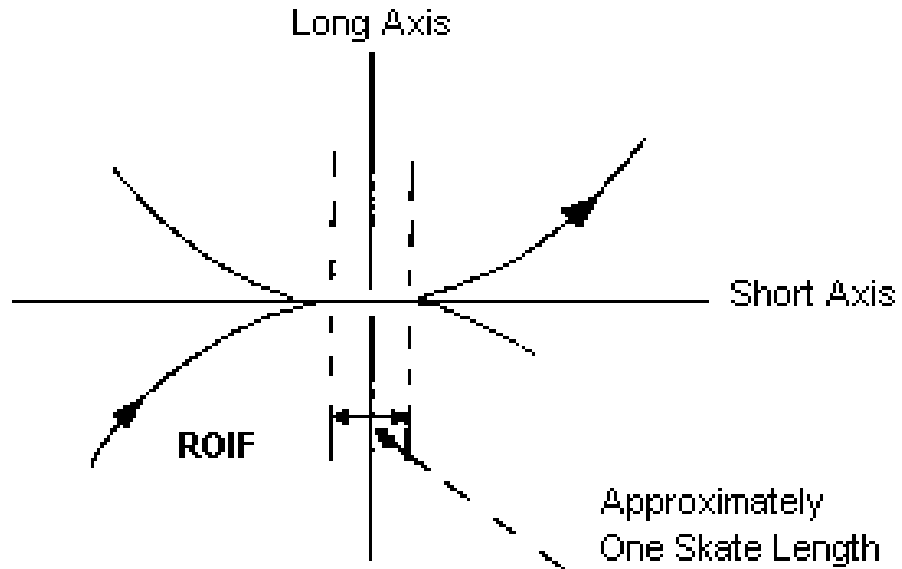

1. All changes of edge should be made at the intersection of the long and short axis, with a smooth, even transition.
2. A good change of edge will produce a flat approximately the length of the employed foot.
3. There is no prescribed action of the free leg on change of edges.

12.1 Common Faults on Change of Edges

1. Cutting across flat on first side of change.

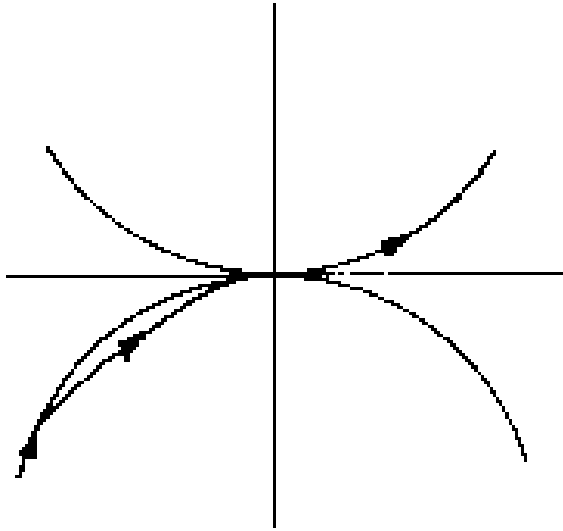

2. Cutting across flat on second side of change.

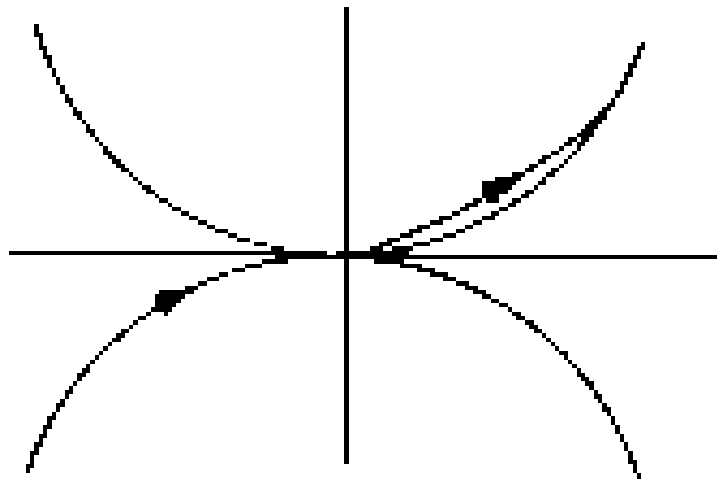

3. Oblique or cutting both sides of change

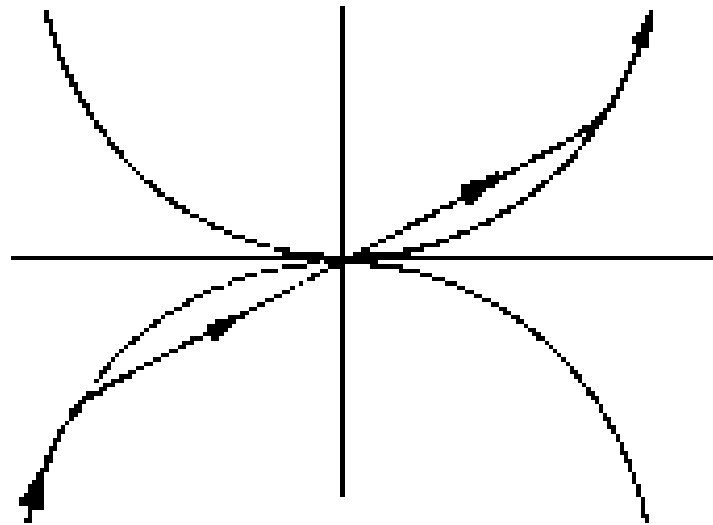

4. Wobble either before or after change.

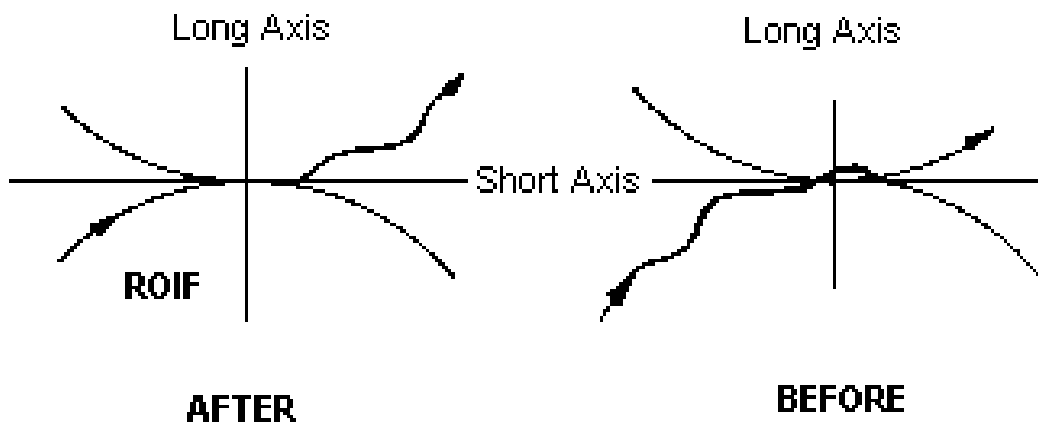

5. Forced change of edge. (Outside edge held too long past long axis)

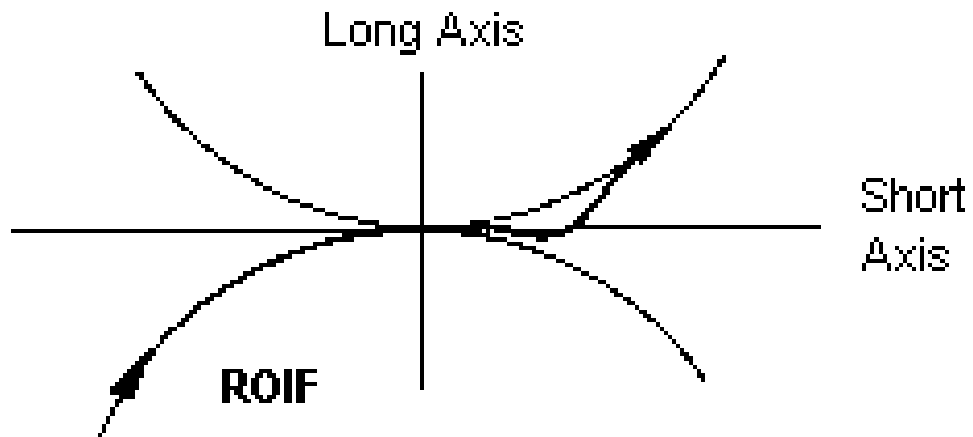

6. "S"ing change of edge.

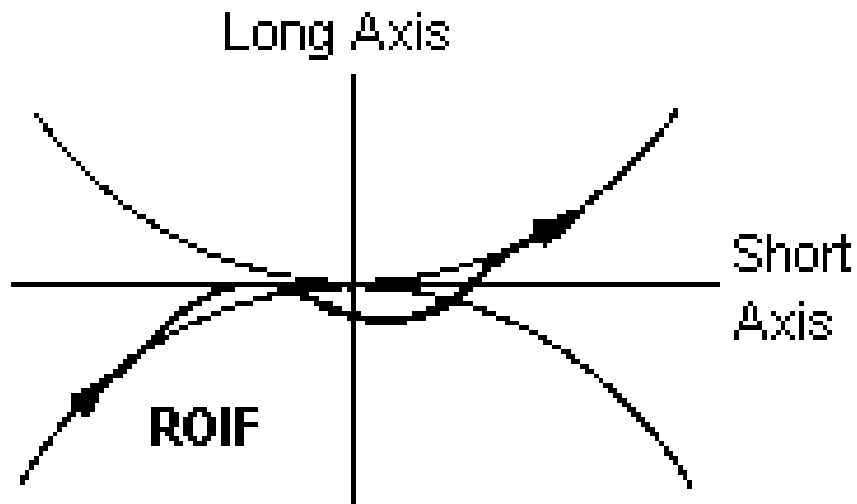

7. Flat too long. (Held more than length of skate)

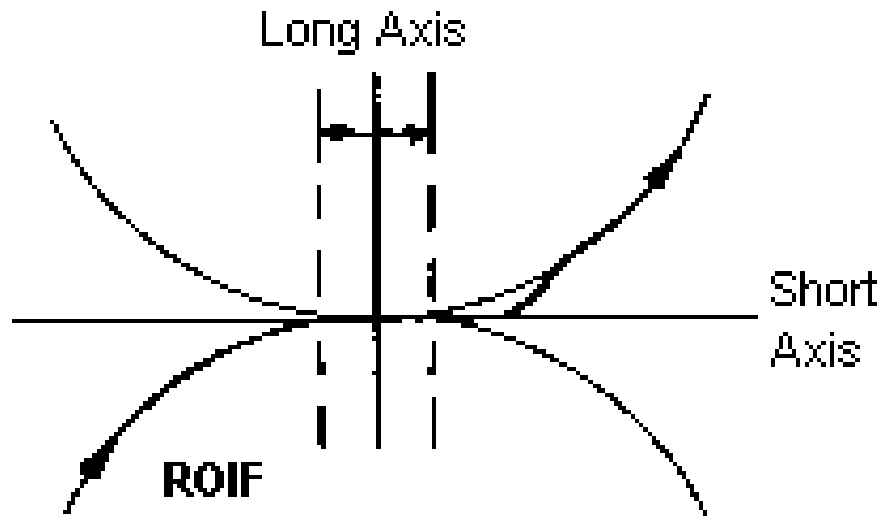

8. Pulling change of edge - gaining speed on change.

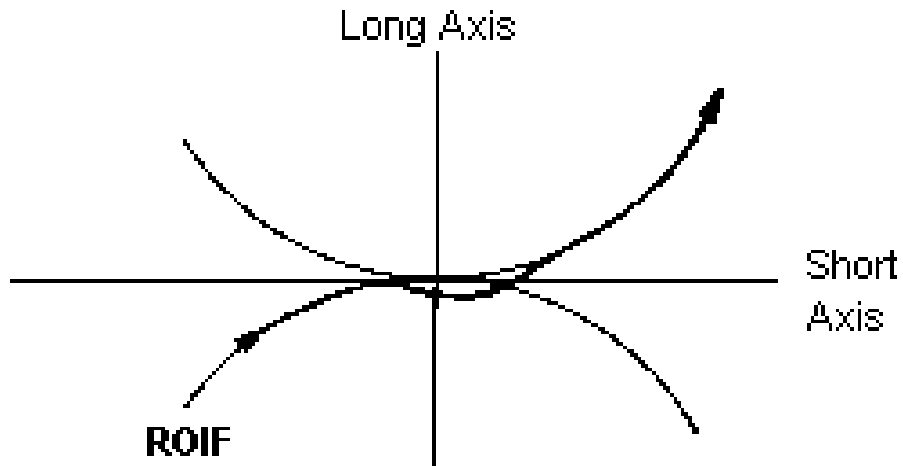

9. Double lean.



13 Three Turns

Figures 7, 8A-B, 9A-B, 26A-B, 27A-B, 34A-B, 35A-B

Cusp - The point of intersection of, and the two small curves comprising, the deviation from the arc. The point of any one foot turn.

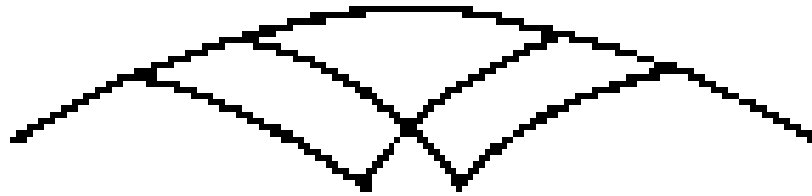

Three (Abr. 3) - A one foot turn from a forward edge to an opposite backward edge or vice versa, with the rotation in the direction of the initial edge, and with the cusp inside the circle.

1. Threes should be made with the turns placed on the long axis.

Diagram:

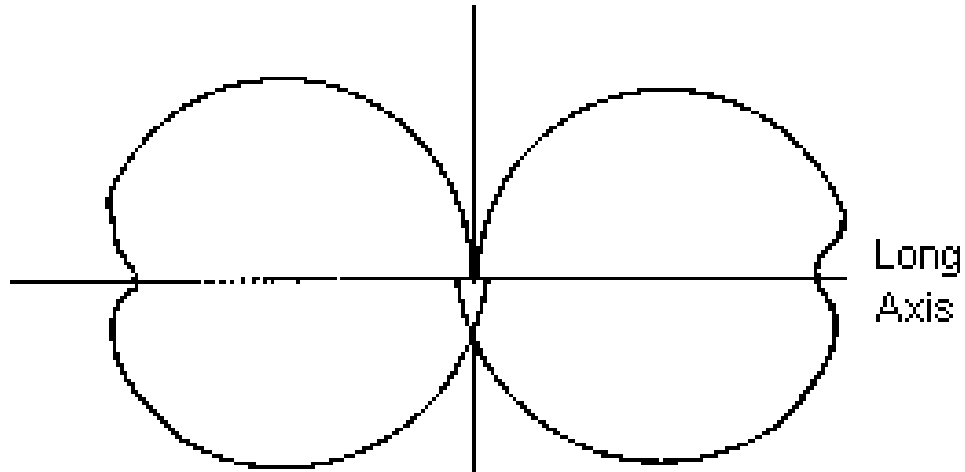

Other Three Figures: 8A-B, 9A-B, 26A-B, 27A-B, 34A-B, 35A-B

NOTE: Figure 7 has a Choctaw Turn in it which must be an IB to an OF edge with no rockover and the thrusting foot leaves the floor by the long axis.

2. The depth of the cusp of the Three Turn shall be one skate length with the skid mark on the circle.

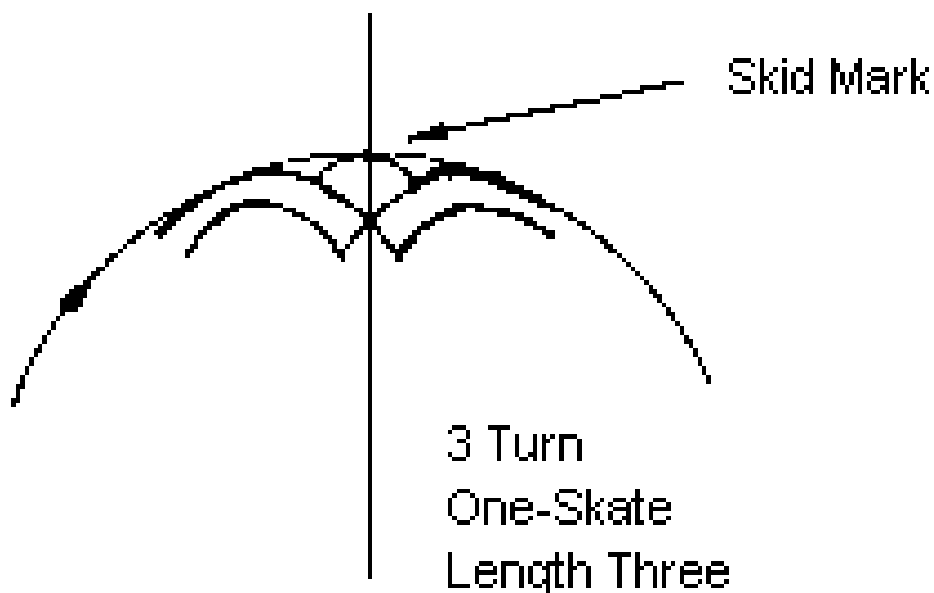

3. For Three Turns the cusp extends one skate length into the circle and the shoulders of the turn are symmetrical.

4. On Three Turns the entrance edge should be held right up to the precise instant of turn, with the new edge assumed when the skate is going away from the long axis.
5. There is no prescribed action of the free leg except on the outer forward Three Turn. In the outer forward three turn, the freeleg must not pass the skating foot and move to a leading position, before the turn.
6. Three Turns should be executed with a smooth even rotation, not jumped or pulled.
7. Three Turns should be done with complete control over the skate at all times, so an even flow or roll through the turn is desired.

NOTE: The skate should not stop during the turn. The speed of entry and exit from the turn should be even. No jerky forward backward motion on turns.

8. Three Turns should be done on at least three wheels on a steady radius. In a good Three Turn any lifting of the fourth wheel should be almost imperceptible to the judges.

13.1 Drawings of Problems on Threes

1. Wobble after Three

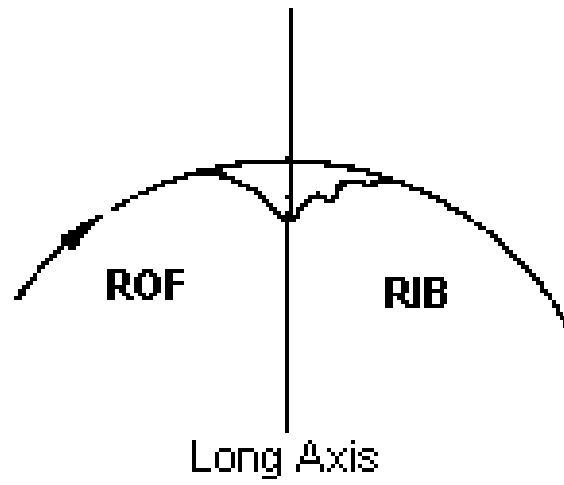

2. Wobble before Three

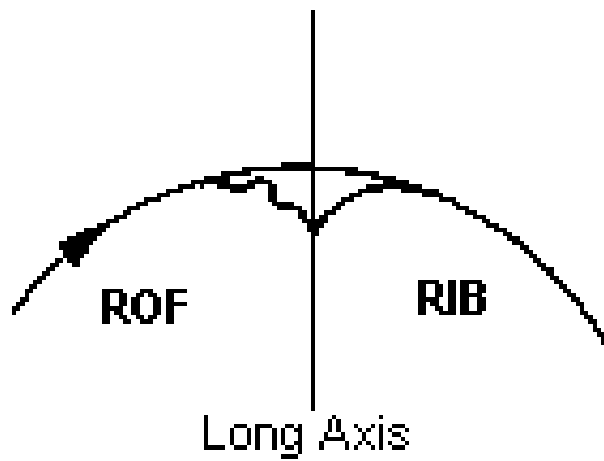

3. Flats before Three

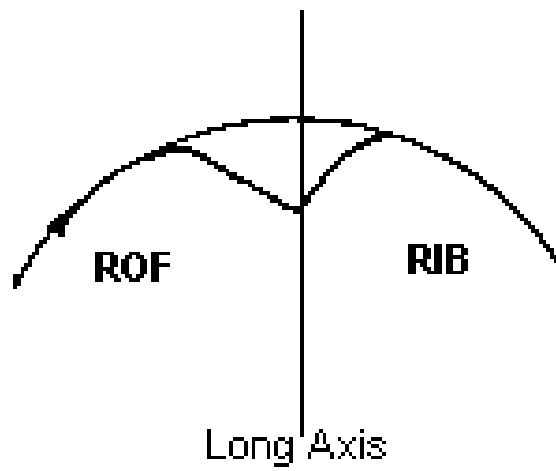

4. Flats after Three

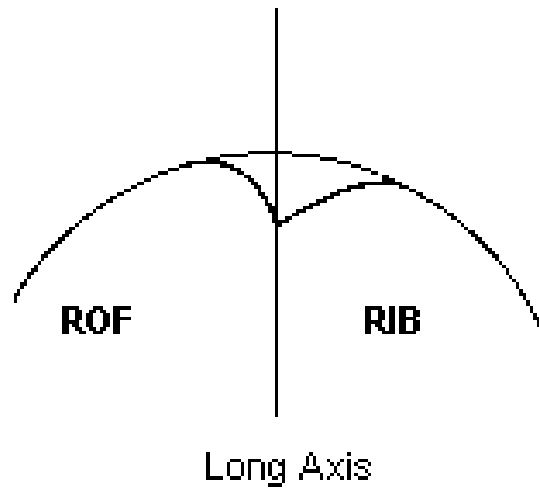

5. Flats both sides of Three

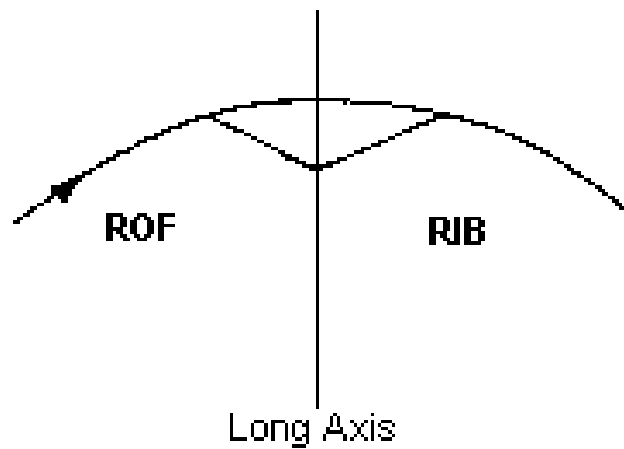

6. Change of edge before Three most common

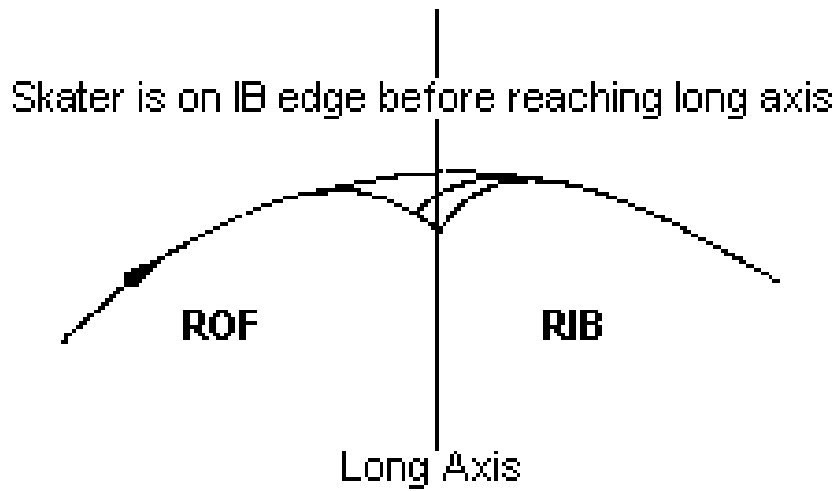

7. Change of edge past Three

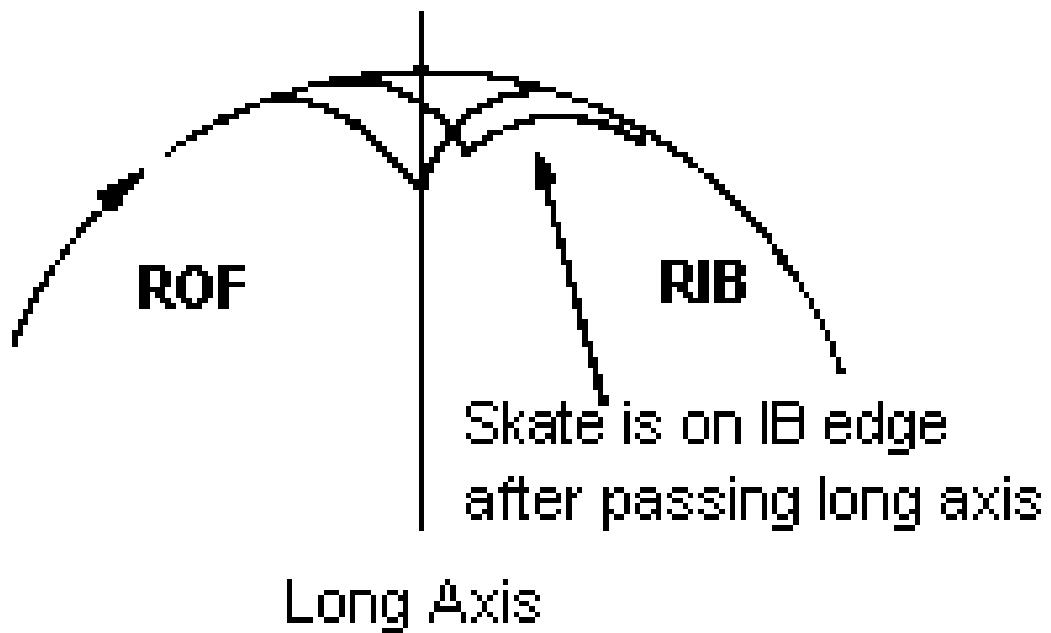

8. Long forced edge before turn

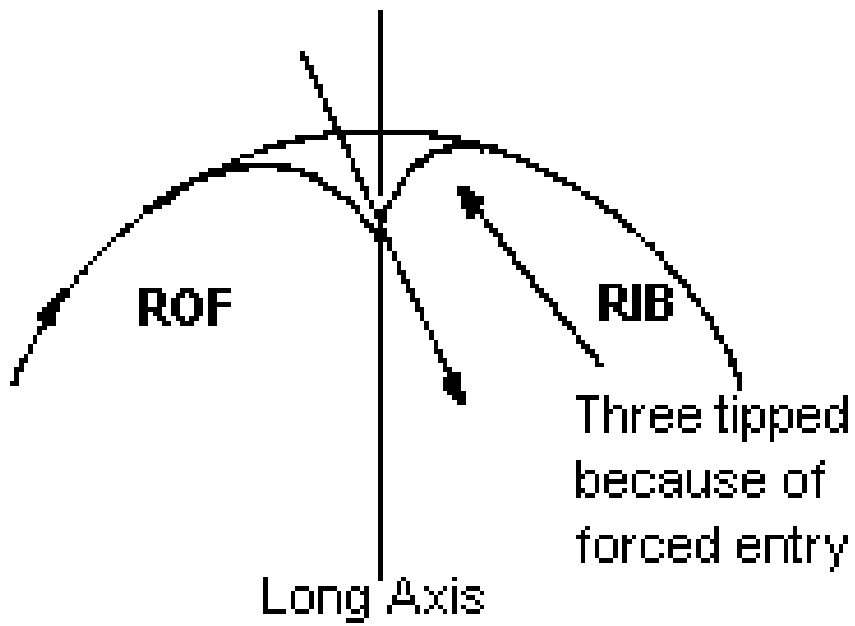

9. Shallow exit after Three

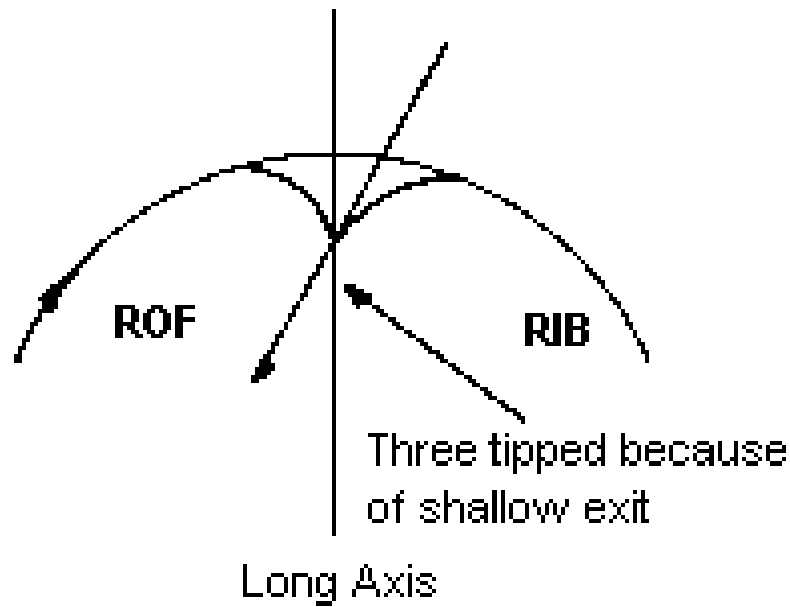

10. Hooked Three

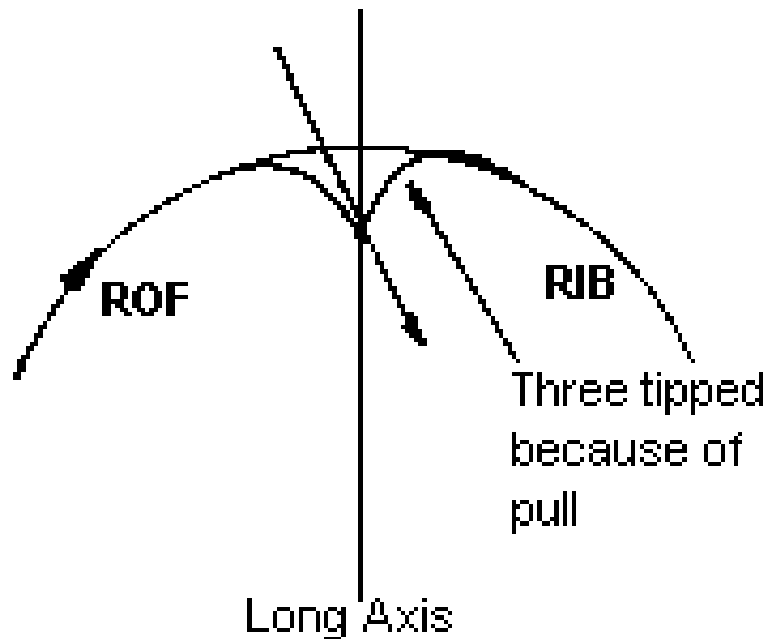

NOTE: Most common error especially in second turn of Double Threes. Pull usually from loss of balance; the skater did not turn around far enough on first curve and has to pull himself out of bad position.

TIP: Increase speed on exit of turn.

11. Bulge after turn

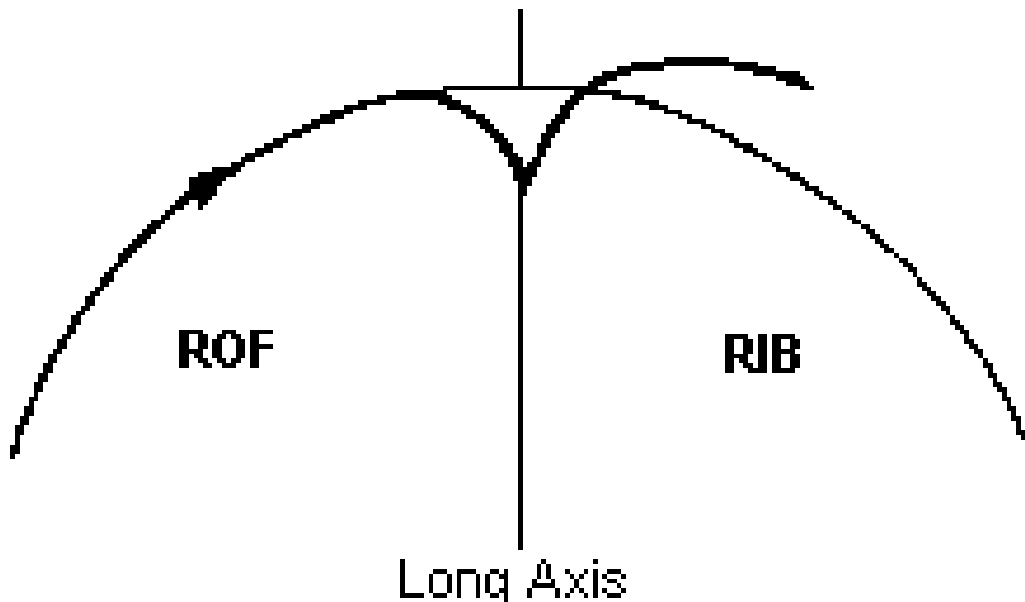

NOTE: Probably an error even worse than falling in (depending on how far) because if the skater went out he probably hit the wrong edge afterwards.

14 Double Threes

Diagram:

Double Threes

Fig. 10 Other Double Three Figures 11, 12, 13, 28A-B, 29A-B, 36A-B, 37A-B.

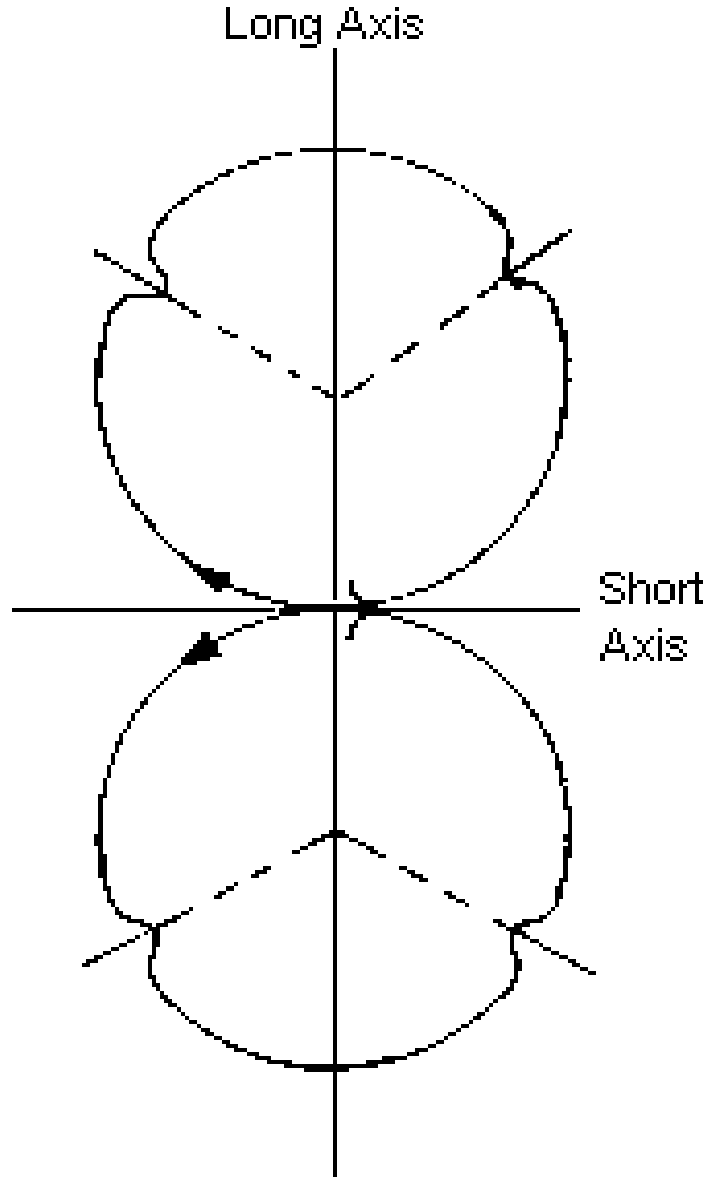

Two consecutive Three Turns are on the same foot and the same arc. The first turn is executed at a point $\frac{1}{3}$ of the way around the circle; the second curve shall cut the long axis at right angles and the second turn is executed at a point $\frac{2}{3}$ of the way around the circle. The point of the cusps should extend into the circle and the shoulders of the turns should be symmetrical and equal.

1. The entrance edge of the cusp should be held right up to the precise instant of turn with the exit edge being assumed when the skate is going away from the point of the cusp.
2. Double Three should be done with complete control over the skate at all times. An even flow or roll through the turns is desired.
NOTE: The skate should not stop during the turn. The speed of the entry and exit from the turn should be even. No jerky forward backward motion on Double Threes.
3. Double Three turns should be done on at least three wheels on a steady radius. Any lifting of the fourth wheel should be almost imperceptible to the judges.

14.1 Judges Observations of Double Threes

1. Judges do not only observe one turn to see if the shoulders of that single turn are even on Double Threes; they must observe and compare the sizes of two different turns and compare the sizes of two different turns and compare their relative sizes.
NOTE: It should be noted that the distance from the centre of the ankle to the toe is much greater than that from the ankle to the heel. For this reason back turns have a tendency to be executed quicker than forward turns, since in turning backward the foot has less distance to travel than when turning forward. This is the reason that by their very nature forward turns have larger slower cusps than back turns. Now the ability to produce these turns evenly, matching the size of the back turn with an even speed of entrance and exit should be rewarded by the judges.
2. The point of cusps should extend into the circle and the shoulders of the turns should be symmetrical and equal. Cusps should be 1 skate length deep.
3. Inside turns also have a tendency to have longer entrance cusps than exits.
4. Outside turns have a tendency to rockover early before the turn.
5. For the forward Double Three, the middle arcs and the second threes are skated backwards, so the judge should position himself so he can readily observe the backward arc and the second backward three.
6. For the backward Double Three the more difficult parts are the backward take-offs and the first threes. In this case the judge should position himself so he can readily observe these sections.
7. Flow and roll of the skate is important in all figures, but in Paragraph Double Threes, pulls out of turns, or in the changes, or any other artificial and incorrect means of maintaining speed are serious faults which judges should watch for.
8. On Paragraph Threes, if the first turn is taken too fast, the following section of the figure sometimes lacks control. The roll on the second turn is often lacking causing sub-curves or flats.

9. For the Forward Paragraph Double Threes, the second and fourth threes are taken backward and hence are trouble spots and often are placed off axis. A judge should position himself so that he can observe the second and fourth threes.
10. For the Back Paragraph Double Threes, the take-offs and changes are backward, and the placing of the first and third threes are difficult. Judges should position themselves so they will have a good view of the first and third Threes
11. . Consistent place and flow throughout the Three Turn Figures is a clue to the symmetry of the shoulders of the turns.

14.2 Drawings of Common Errors on Double Threes

1. First turn off axis early

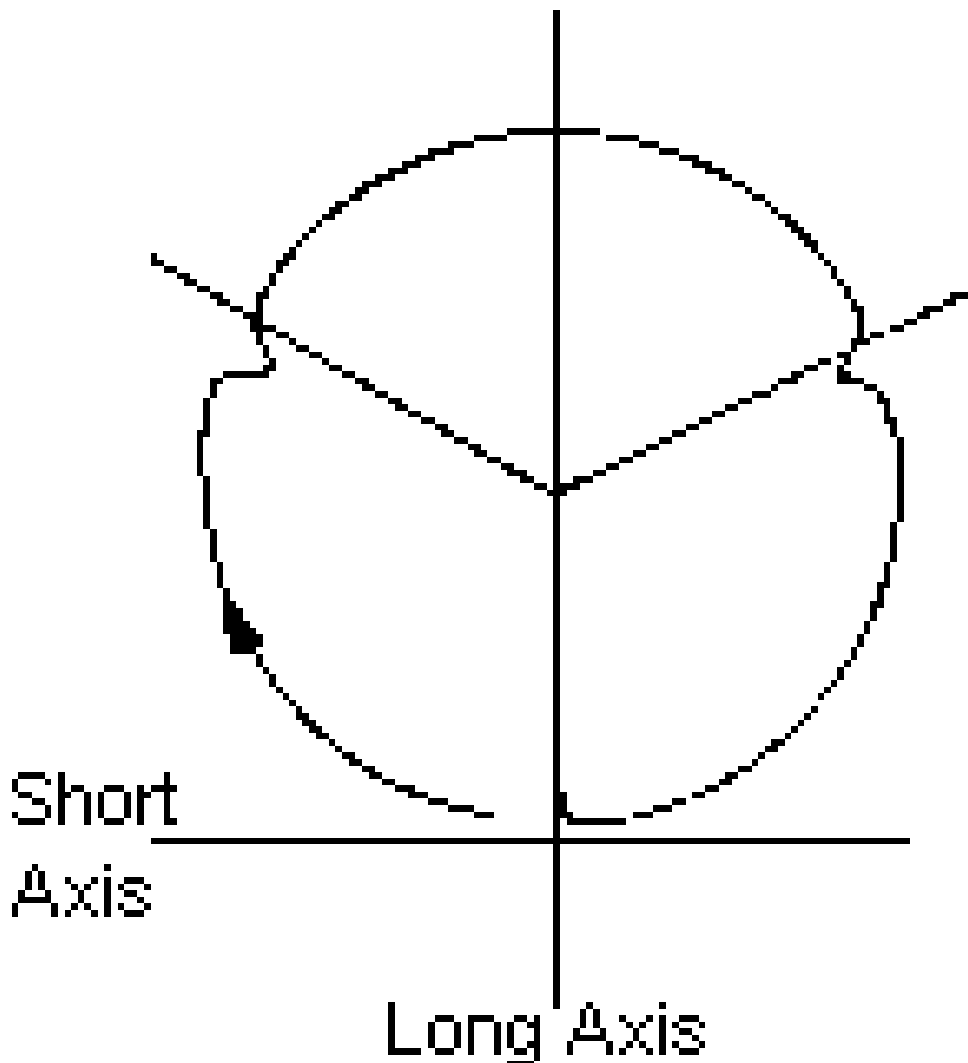

- 2 First turn off axis late

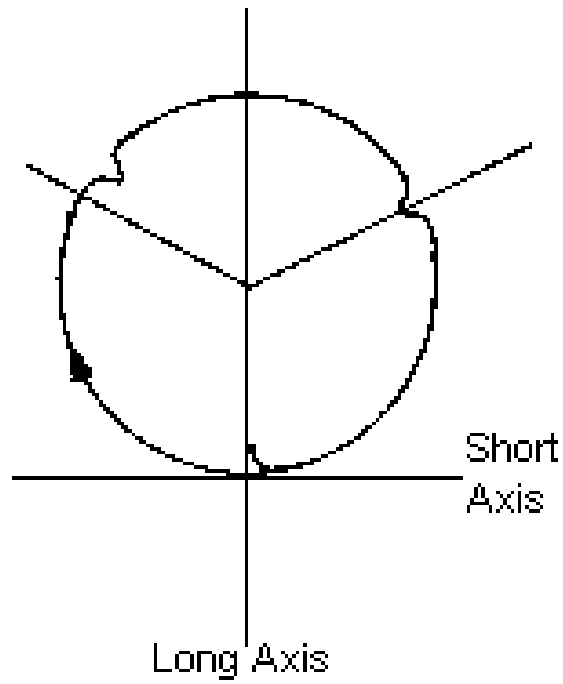

- 3 Both turns off axis; both early

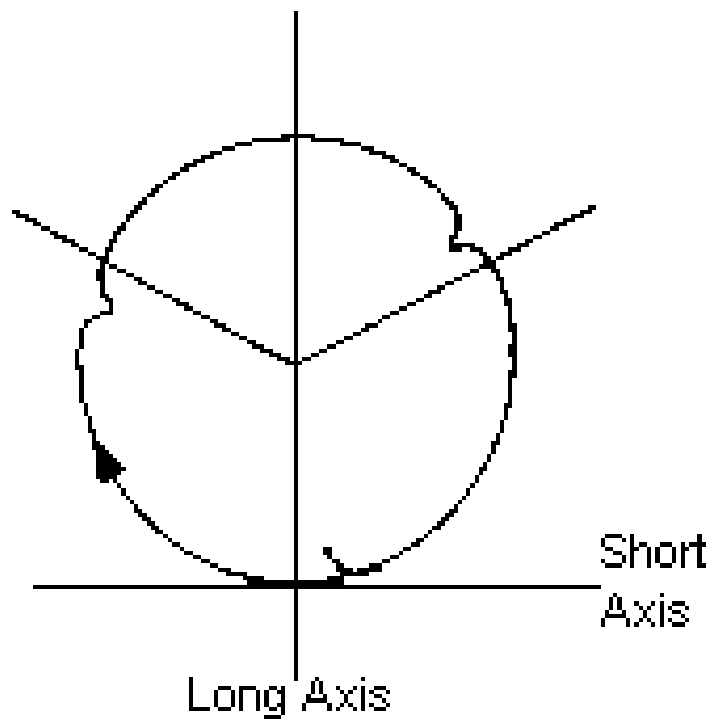

NOTE: This is the most common error in placement of Double Threes.

4 Cutting circle off after three

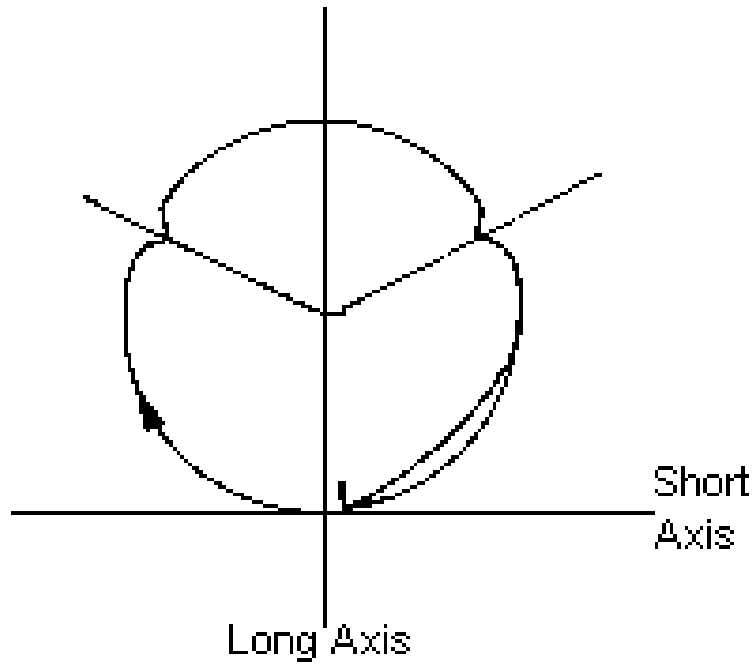

NOTE: The closer to the three this happens, the more serious the error.

5 Flat across top of circle

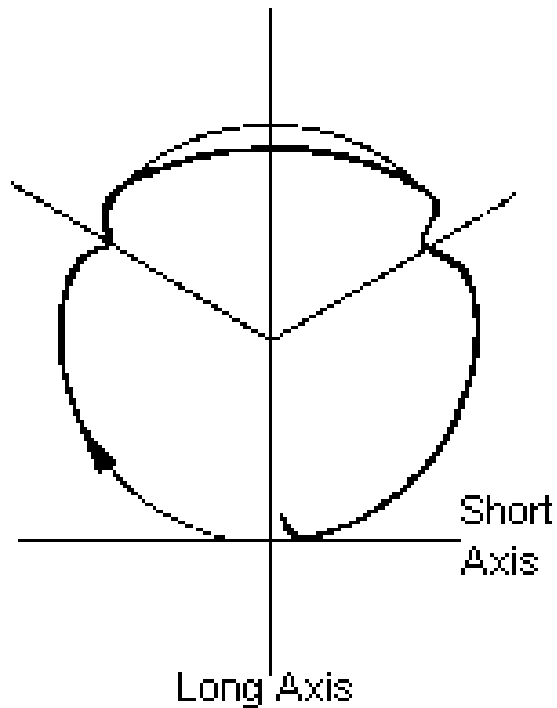

- 6 Wobble across top of circle

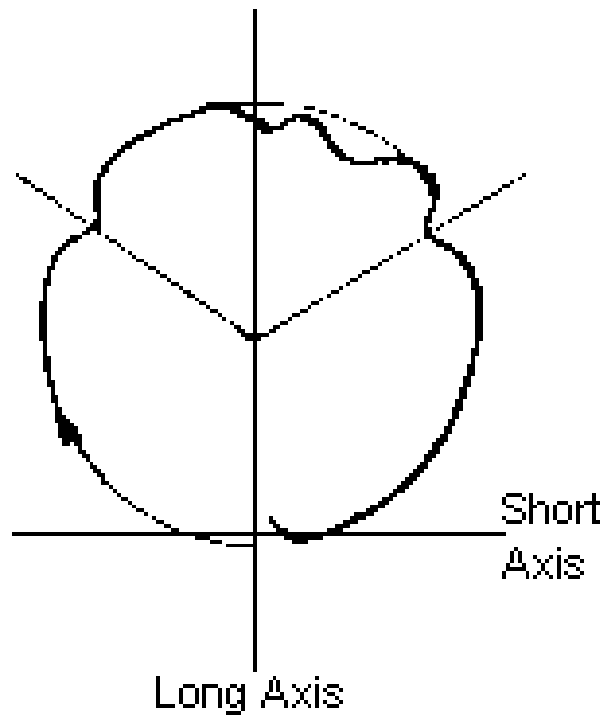

- 7 Long flat early departure from radius of circle for turn

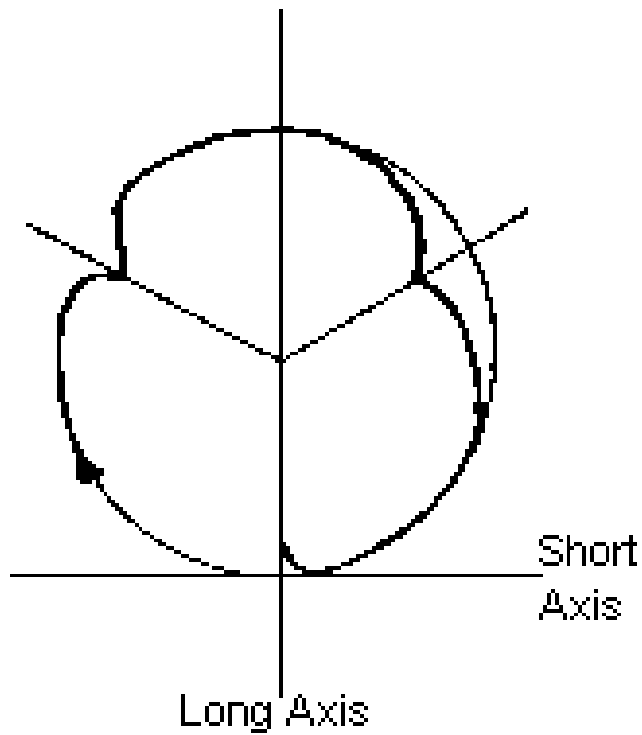

NOTE: One of the most common errors on Double Threes.

- 8 Bulge out over top of circle

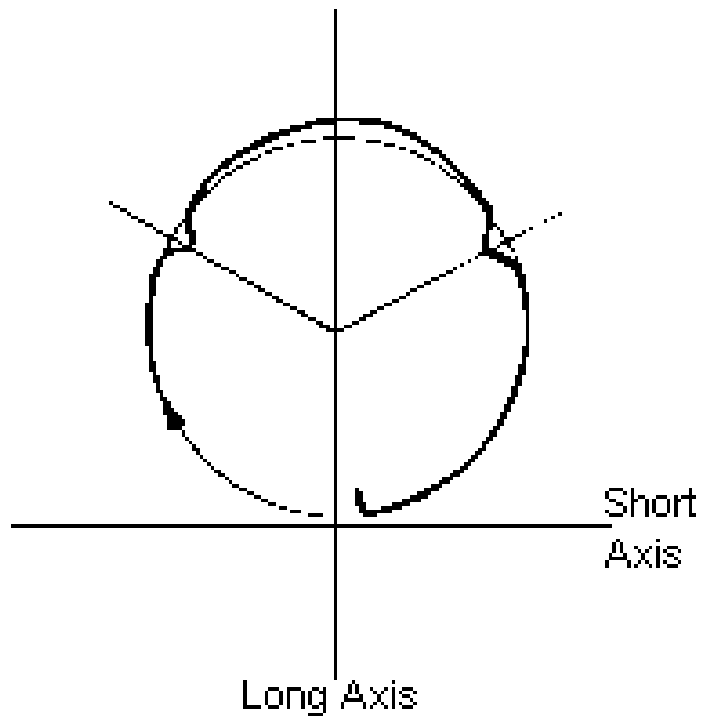

- 9 Bulge out before second Three

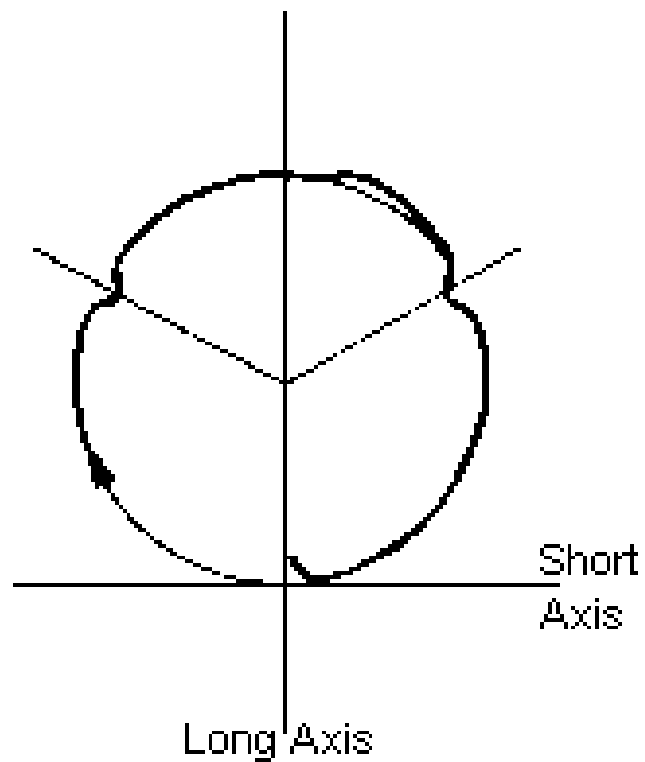

NOTE: This error is another common error, and is compounded if the lean goes outside the circle and the skater rocks over before the turn.

10 Both Threes not pointing to the centre of the circle

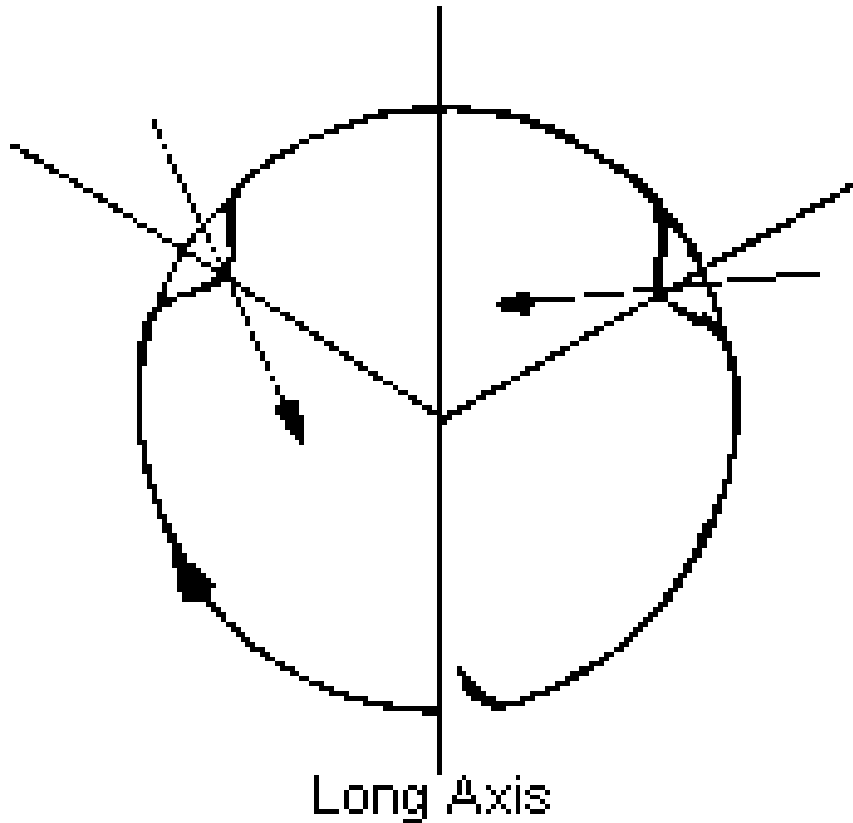

NOTE: If the first shoulder of the Three has a long flat the Three will point the opposite directions from the diagram.

The first Three, a forward, had a much flatter, longer, second shoulder.

The Second Three, a backward, is the same type of error, but this is where the Three points on the same flat exit backwards.

15 Brackets

Figures 18A-B, 19A-B, 32A-B, 40A-B, 41A-B

Bracket - A one-foot turn from a forward edge to the opposite backward edge or vice versa; the rotation of the turn is contrary to the original edge.

1. The Bracket should be turned at the long axis with a cusp pointing out of the circle, not exceeding one half the length of the skate.
2. Brackets should be made without a change of edge before or after the turn and the first and second curves should be of the same size.
3. The Bracket turn is not a natural turn; while the body is leaning into the main circle, the skate is forced to curve in the opposite direction and away from the centre of gravity. This turn requires a quick, precise turn in a short space.

15.1 Important Judging Tips on Brackets

1. In the forward to backward Brackets there are likely to be errors during the preparation for the turns. Errors before Bracket turns are serious errors because they incorrectly facilitate the making of the turn. In extreme cases a change of edge may even occur before the turn.
NOTE: Keeping this in mind, a good position for a judge to observe Brackets would be on the side of the figure nearest the skater's approach to the Bracket, but not excluding the view of the exit edge.
2. In the backward to forward Brackets, there are likely to be errors on the exit edges. The judges should be alert that a change of edge frequently occurs here.
3. Flow and roll of the skate is very important on the Paragraph Brackets. Here again, pulls out of the turns or in the change or any other artificial and incorrect means of maintaining speed are serious faults.
NOTE: It is advisable on Paragraph Brackets, and in all Paragraph Figures, to stand in position near the take-offs, so that a judge can move to a position to see both turns.
4. In the Forward Serpentine Brackets and also the Forward Paragraph Brackets, bulges out after the first turns are common.
5. In the Backward Serpentine and also the Backward Paragraph Brackets, skaters very often cusp inward to make the first back Bracket.
6. In Bracket Figures inside Brackets are very often more shallow than outside Brackets. Even cusps on inside and outside Brackets are fine points, which should be rewarded by the judges.
7. There is no prescribed free leg action on Brackets.
8. Bracket Turns should be done on four wheels.

15.2 Drawings of Brackets

1. Correct Bracket 1/2 skate length
Turn points out of circle at the long axis

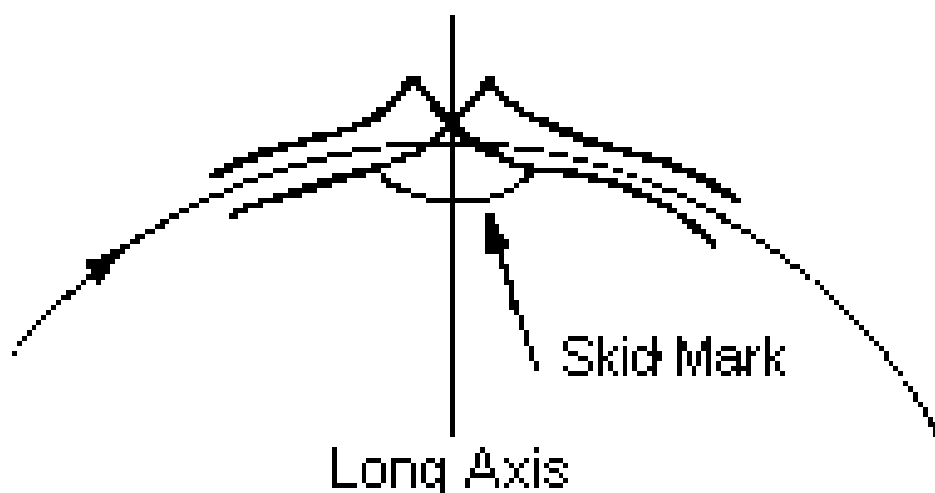

2. Long flat before turn; insufficient rotation.
Turn points in wrong direction

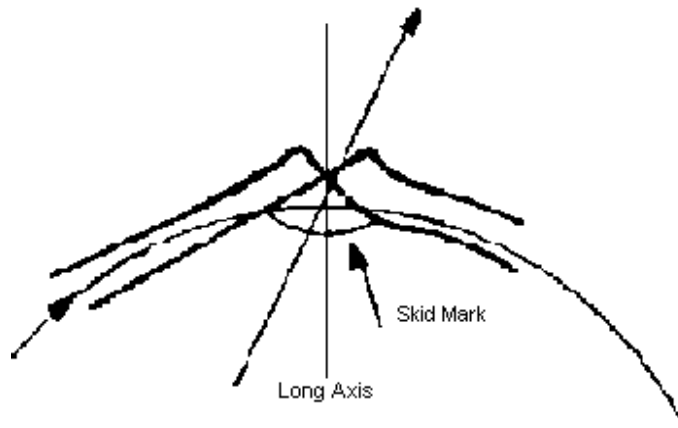

3. Long flat after turn; failure to stop rotation.
Turn points in wrong direction

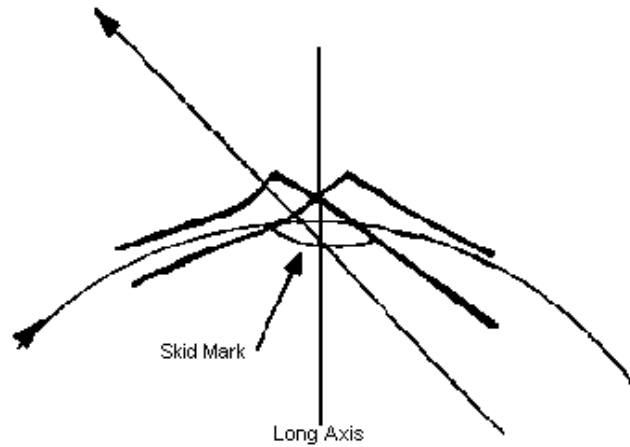

4. Rockover before turn; second edge assumed before long axis; entry cusp shoulders deeper than exit shoulders.
Turn points in wrong direction

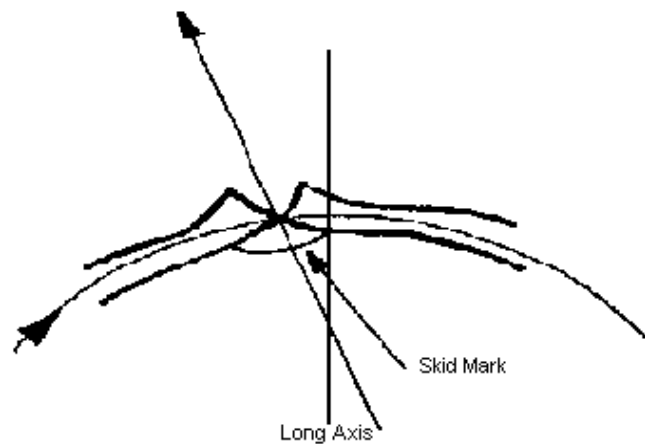

NOTE: Common on forward turns.

5. Rockover after turn; first edge held past long axis.
Turn points in wrong direction

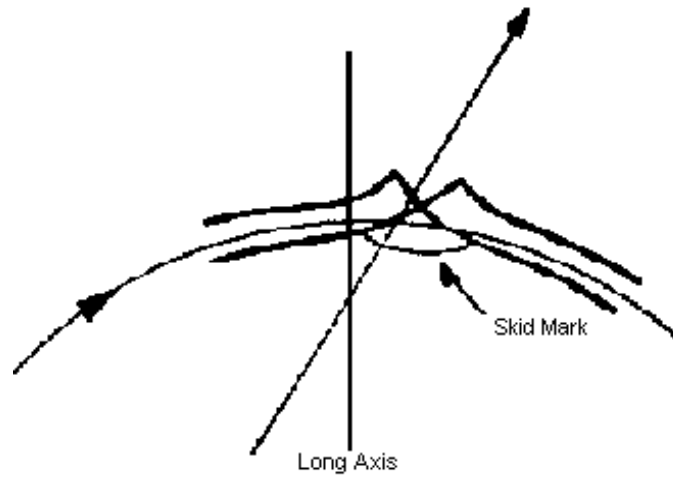

6. Bracket cuts in before turn.

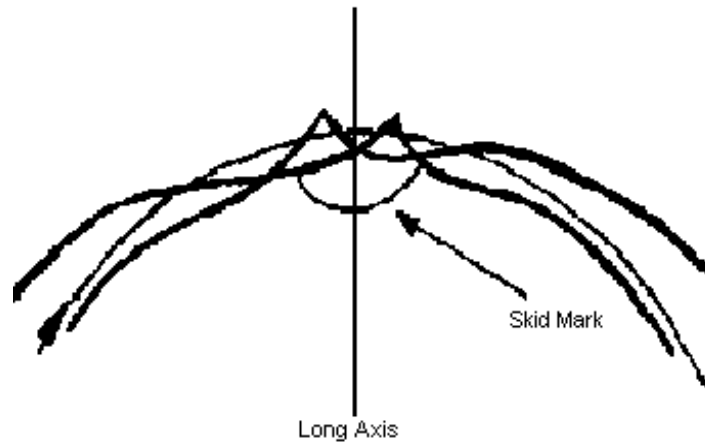

NOTE: A common fault on the OB Brackets

7. Turn points in wrong direction; hooked bracket; second cusp pulled back to line too abruptly

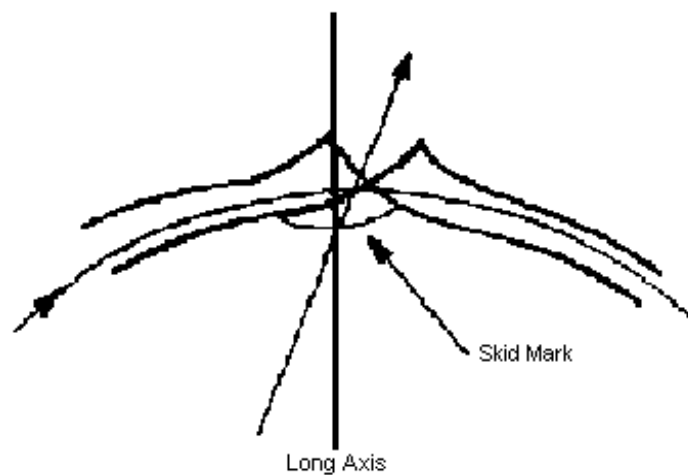

8. Sub-curves before bracket.

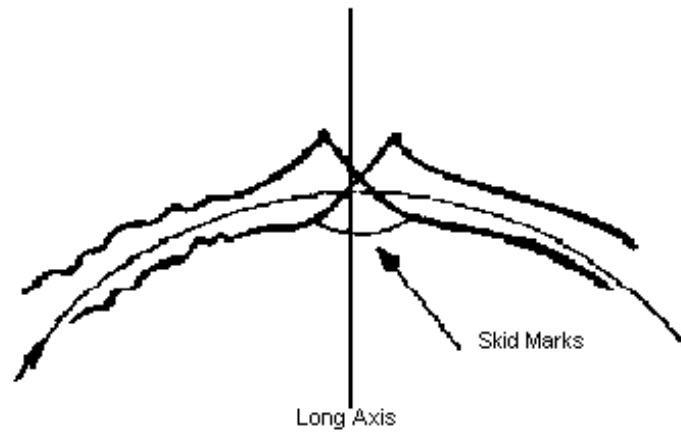

9. Sub-curves after bracket.

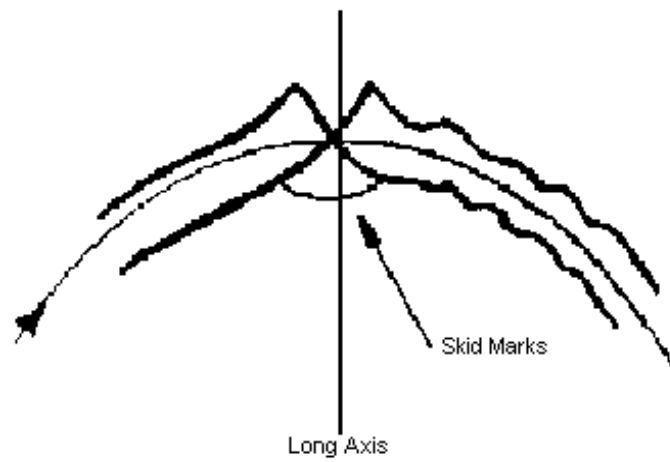

10. Flat bracket.

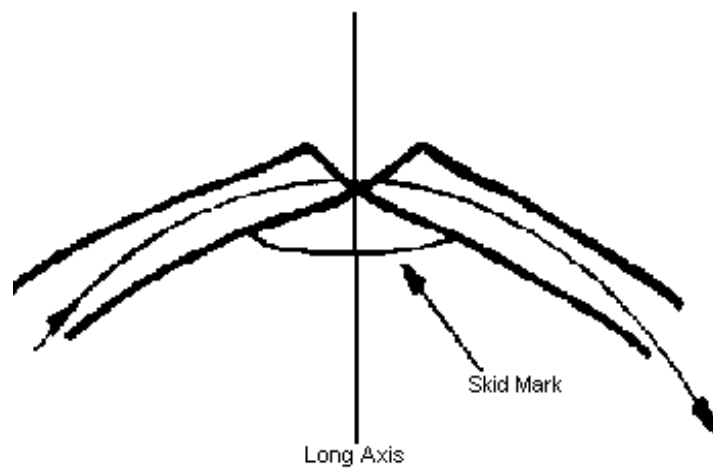

NOTE: Common error - Bracket would be unduly small in relation to the size of skater's foot. Usually characterised by not keeping weight to centre of the circle being skated; the lead rollers would not have left the line

16 Counters

Figures 22A-B, 23A-B

Counter (Abr. CO) - A one-foot turn without a change of edge, with the rotation counter to the direction of the initial edge.

1. The Counter should be done without a change of edge and the turns should be placed on the long axis with a cusp not exceeding one half the length of the skate.
2. There is no prescribed free leg action.

16.1 Important Judging Tips on Counters

1. There should be no flats or sub-curves before or after Counter Turns.
2. Judges should watch for either pulls at the turns (picking up speed or losing speed in turns).
3. Counter Turns should be quick and precise with an even roll throughout the turn.
4. In the Counter Turn errors are more likely to be made in the entrance edge. A judge should position himself opposite the centre circle so he has a good view of both sides of the turn, but in particular the troublesome entrance edge.
5. On Counter Turns, artificial and incorrect means of maintaining speed are serious faults.
6. Everything violent, stiff or angular is to be avoided.
7. Counter Turns should be done on four wheels.

16.2 Drawings of Counters

1. Correct Counter.

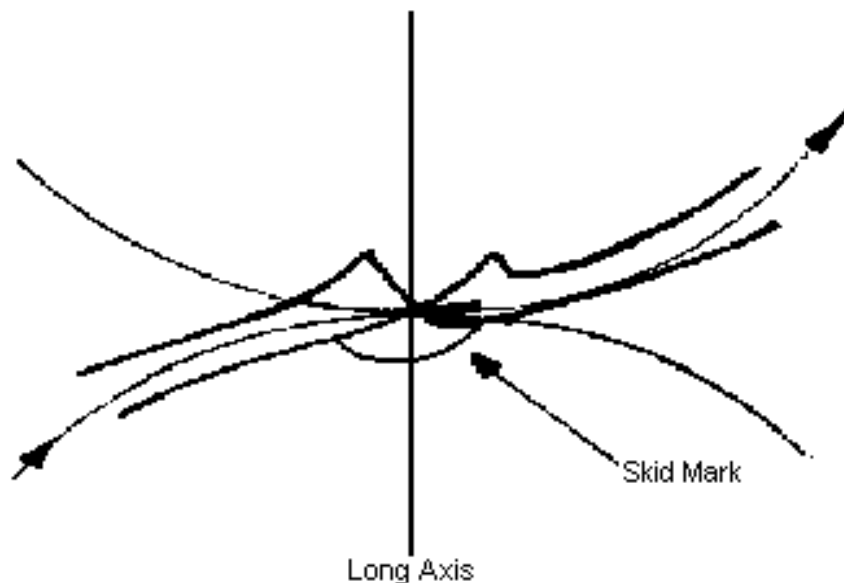

2. Change of edge before turn (actually a Three Turn).

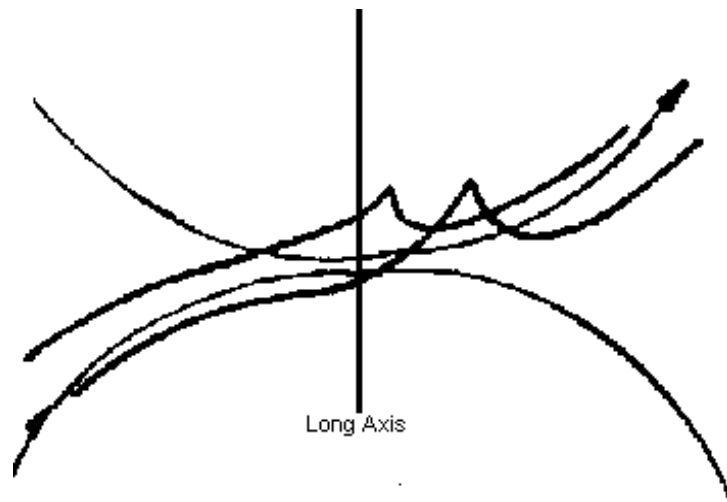

NOTE: This is the most common error in Counters

3. Sub-curve after Counter.

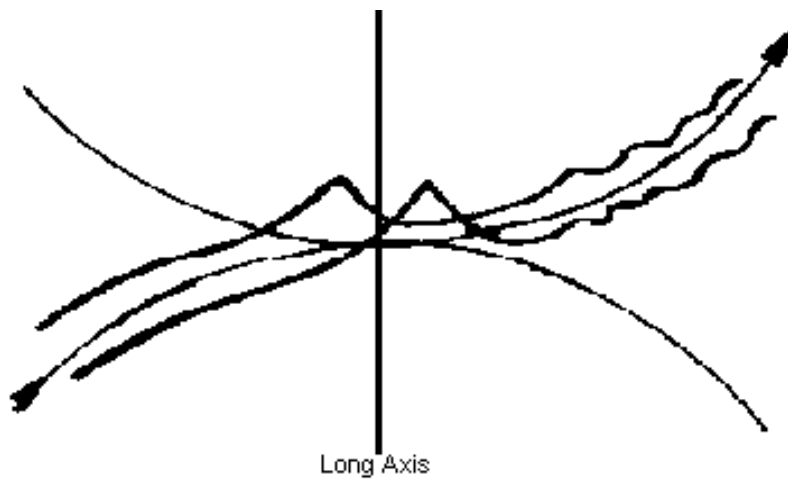

4. Sub-curve before Counter.

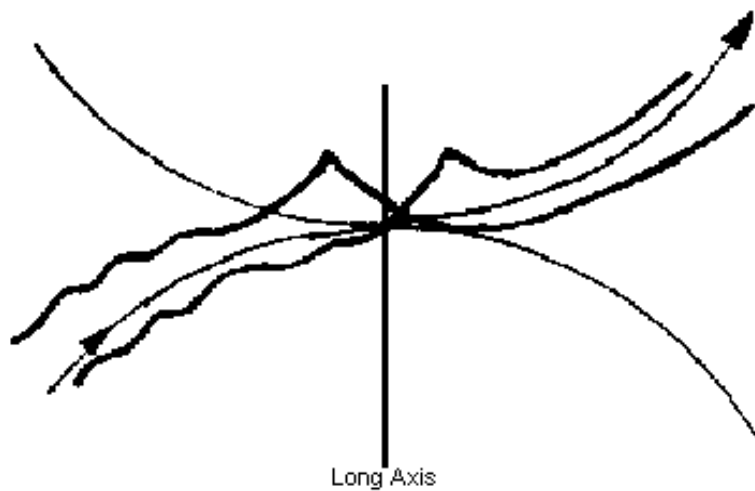

5. Long flat on entrance side of Counter, another common error on Counters.

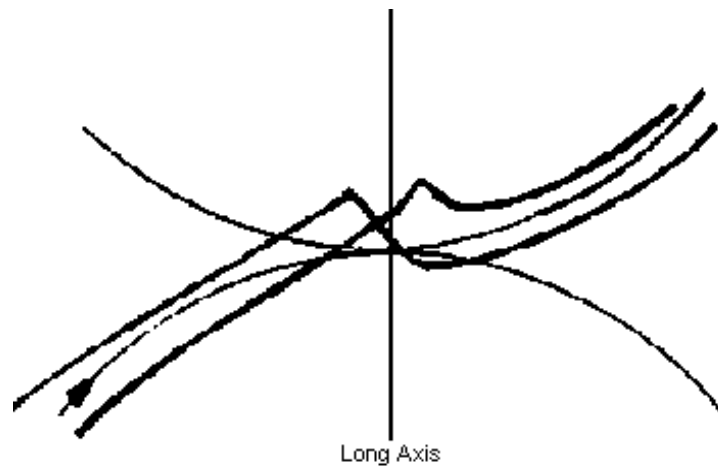

NOTE: This can be observed by an extreme flattening of lean before turn or a double lean before turn.

6. Long flat on exit side of Counter.

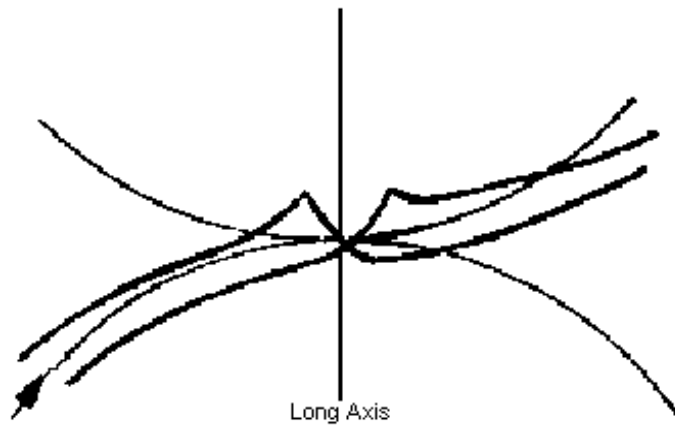

7. Flat Counter.

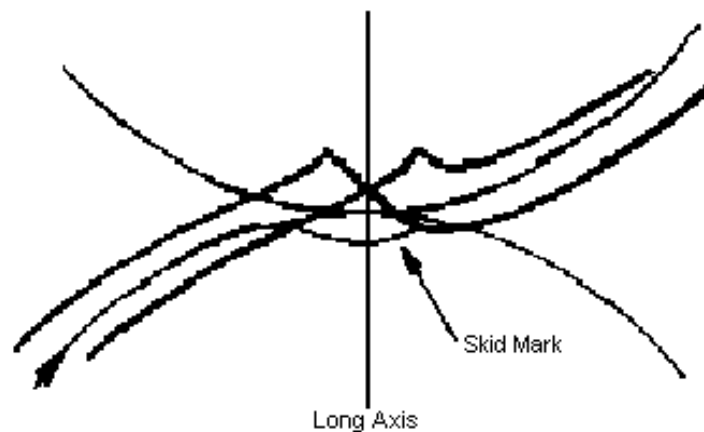

NOTE: Counter would be unduly small in relation to the size of skater's foot. This can be observed by extreme flattening of lean before turn or a double lean before turn. The lead rollers will not leave the line.

8. Counter off axis.

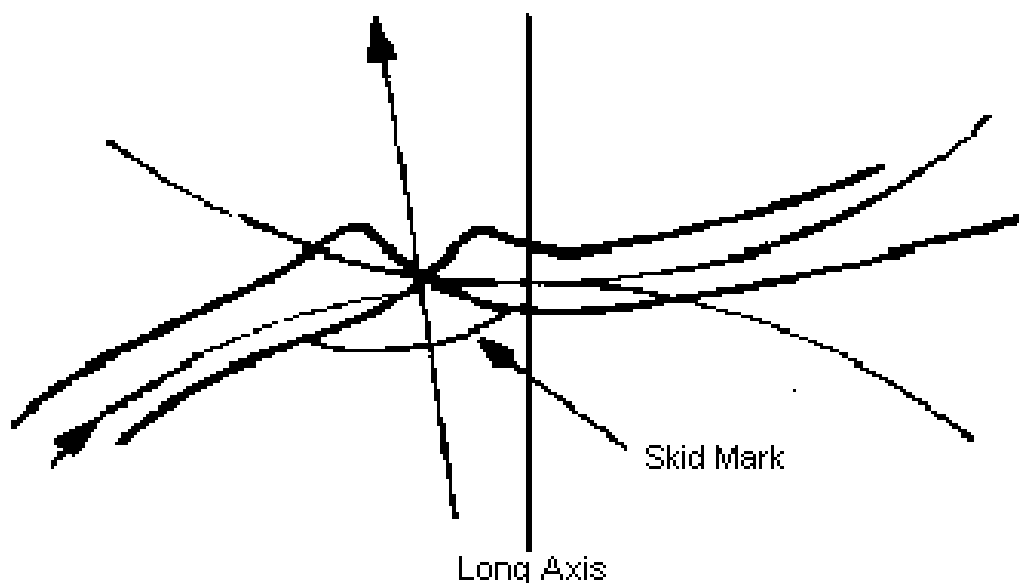

17 Rockers

Figures 20A-B, 21A-B

Rocker (Abr. RK) - A one-foot turn from a forward edge to a similar backward edge, or vice versa, with rotation continuous with the initial edge, and with the cusp inside the original circle.

1. Rockers should be made without a change of edge and the turns should be placed on the long axis with a cusp not exceeding one half the length of the skate.
2. There is no prescribed free leg action.

17.1 Important Judging Tips on Rockers

1. There should be no flats or sub-curves before or after Rocker Turns.
2. Judges should watch for either pulls at the turns (picking up speed) or losing speed in turns.
3. Rocker Turns should be quick and precise with an even roll throughout the turn.
4. In the Rocker Turn errors are more likely to be made in the exit edge, so a judge should position himself opposite the centre circle. From this vantage point he can observe both sides and in particular the troublesome exit edge.
5. On Rocker Turns any artificial and incorrect means of maintaining speed are serious faults.
6. Everything violent, stiff or angular is to be avoided.
7. Rocker Turns should be done on four wheels.

17.2 Drawings of Rockers

1. Correct Rocker.

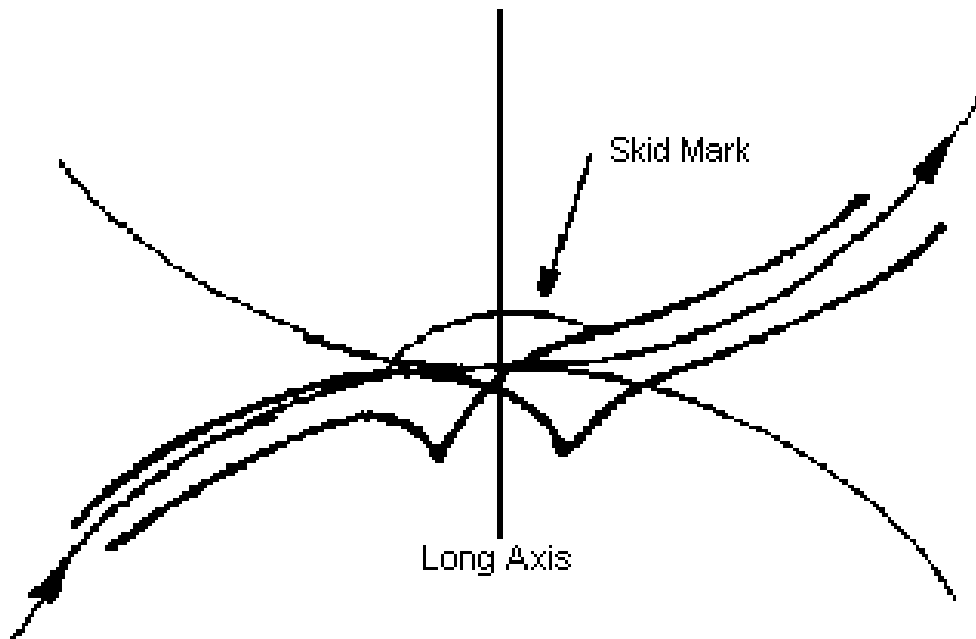

2. Edge too deep, too soon; improper edge before assuming correct edge; change of edge after turn (Three Turn).
Turn may point in right direction.

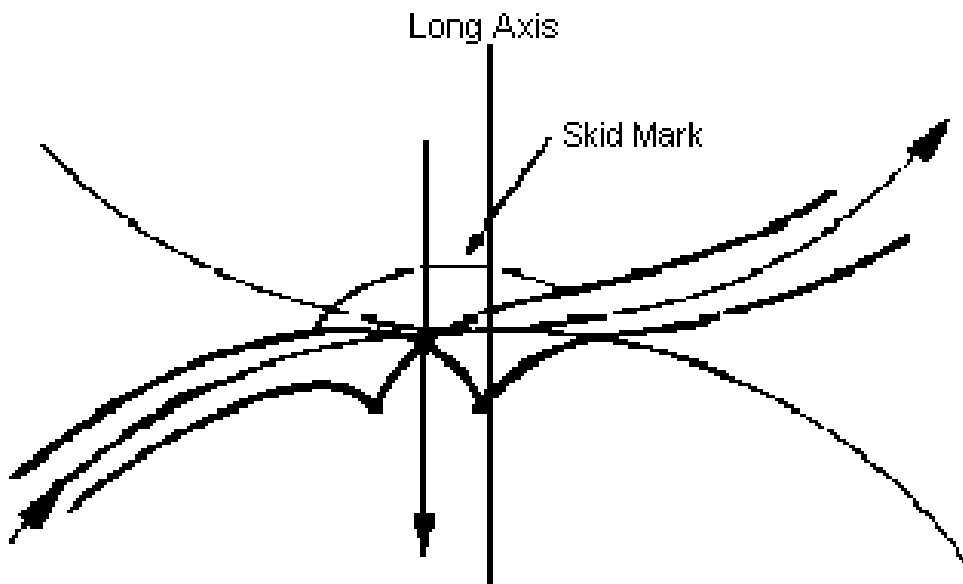

NOTE: Most common fault in Rockers

3. Sub-curves after Rocker.

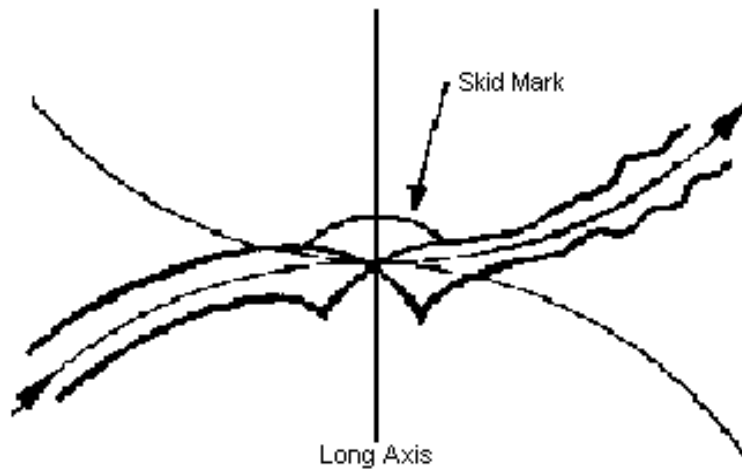

4. Sub-curves before Rocker.

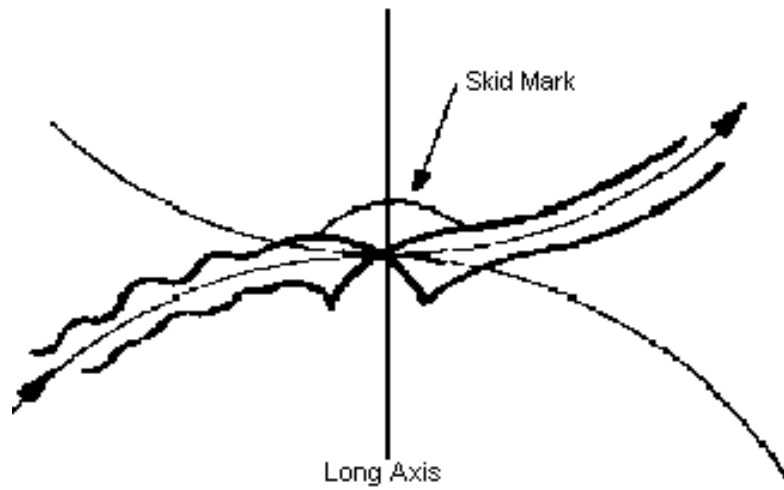

5. Long flat before turn.

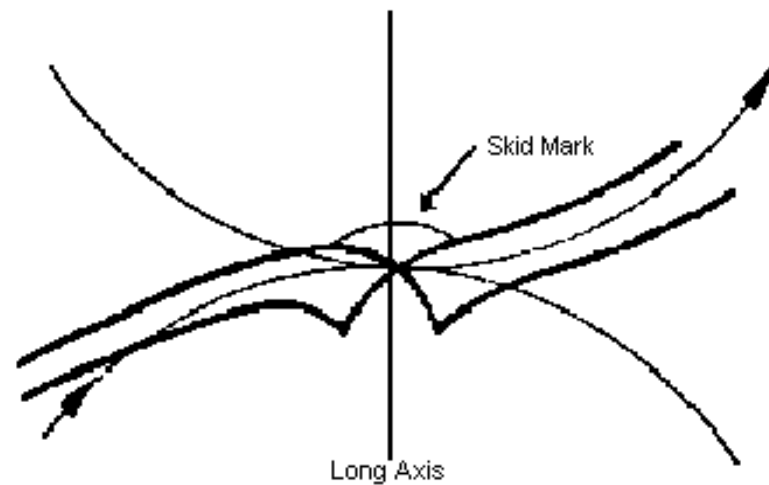

6. Long flat after turn.

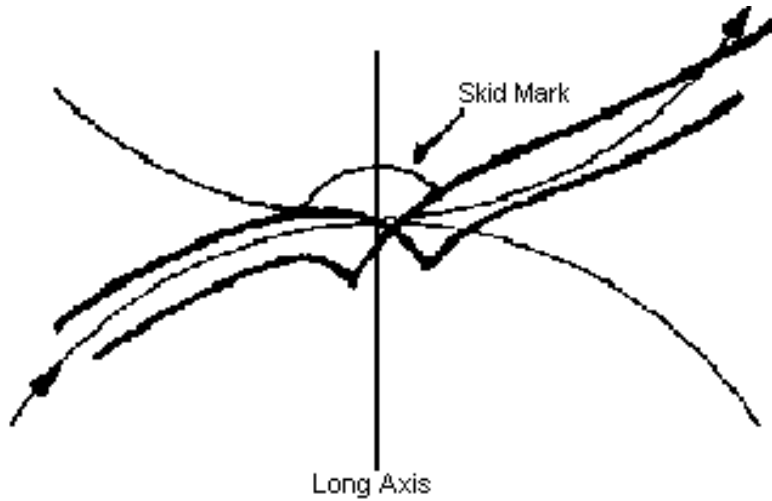

7. Flat Rocker; flats on both sides of Rocker

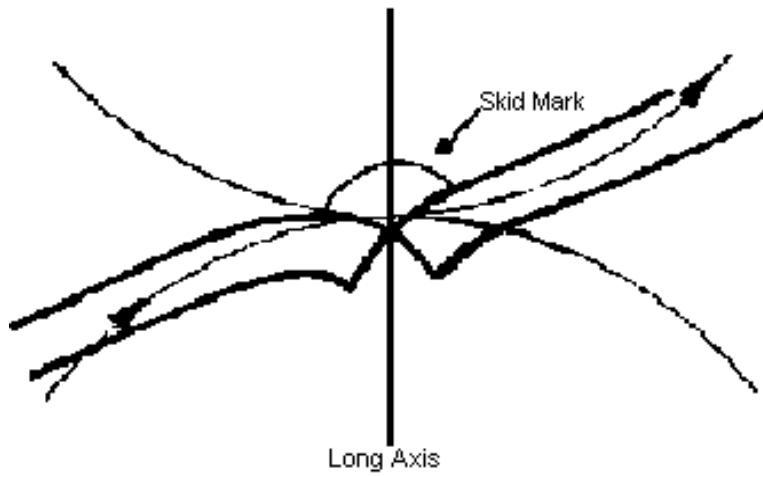

NOTE: This turn is characterised by double leans or lean being unduly flattened during turn. Cusp will be unusually small for size of foot. The lead rollers would not have left the line.

8. Good turn, but just late off axis Rocker.

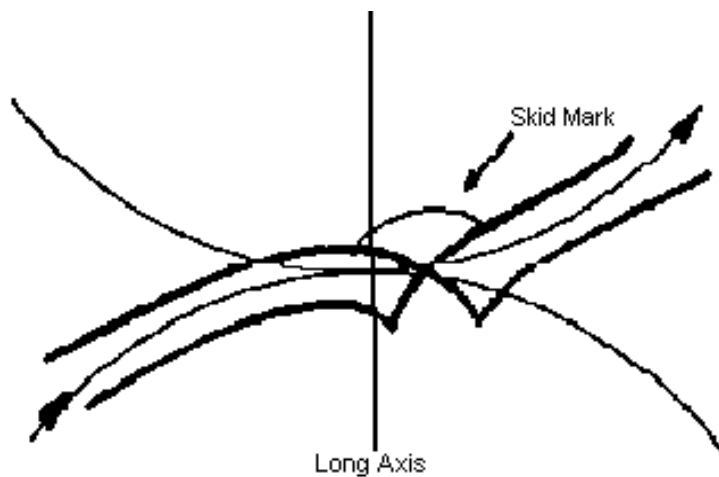

9. Change of edge before turn.

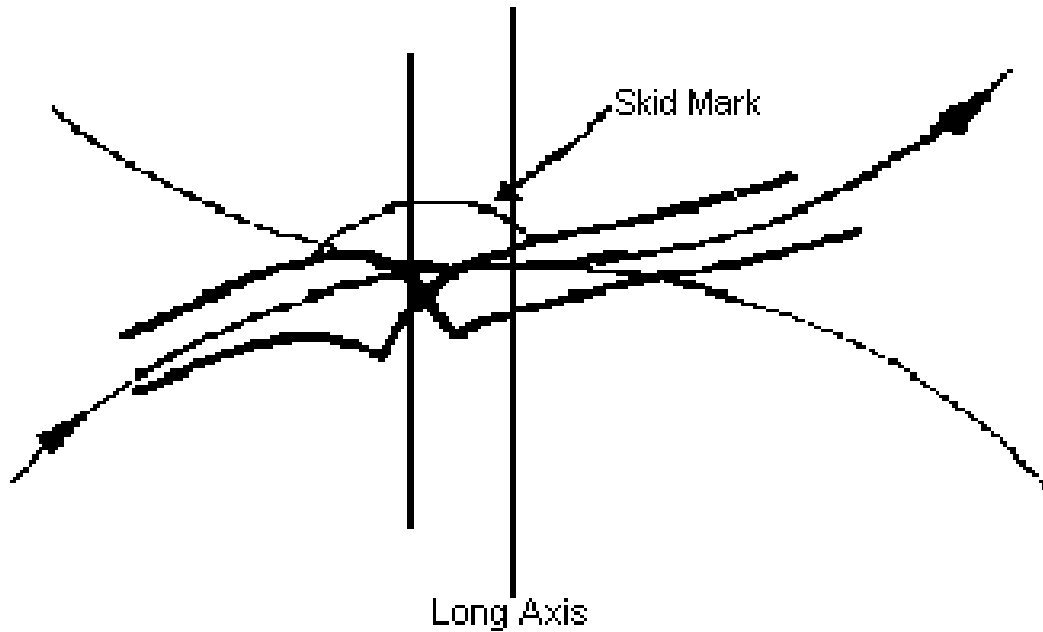

18 Loops

Figures, 14, 15, 16, 17, 30A-B, 31A-B, 38A-B, 39 A-B

Loop Figures - Loops are skated on two or three circles and the loops should be longer (approximately 1/3 of the diameter of the circle) than broad, without an angular change of curvature, with their long axis same as the eight and the second curve should be the same size as the first.

Loop Figures = 2.4 Meters (7 ft. - 10.5 in.) in diameter.

Length of Loop - 23.6 in. or 60 cm.

Width of the Loop - 15.75 in or 40 cm.

1. All Loops should be judged for size and shape.
2. Judges should watch for pulls either out of the Loops or during the changes.
3. Loops should have even roll of the skate both on their entrances and exits.
4. Loop tracing shall be that the leading wheels shall slide around and the trailing wheels shall roll around the loop.

18.1 Important Judging Tips on Loops

1. A judge should stand in a position where he can best observe pulls either out of the Loops or on the changes.
2. A judge should be in a position to see touch downs of the free foot, and to evaluate them as to their severity.

18.2 Drawings of Loops

1. Correct Loop.



2. Sub-curve after Loop.



3. Sub-curve before Loop.



4. Cutting off bottom of Loop.

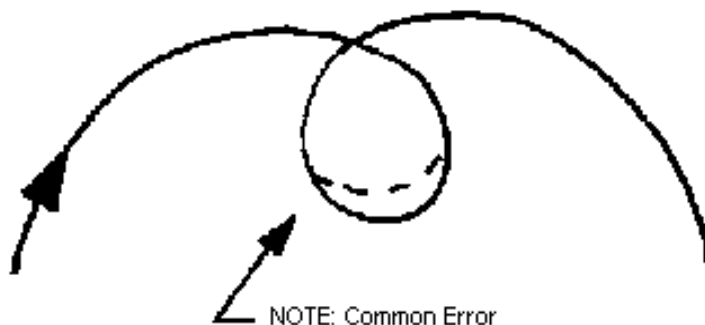

5. Cutting off entrance side of Loop.

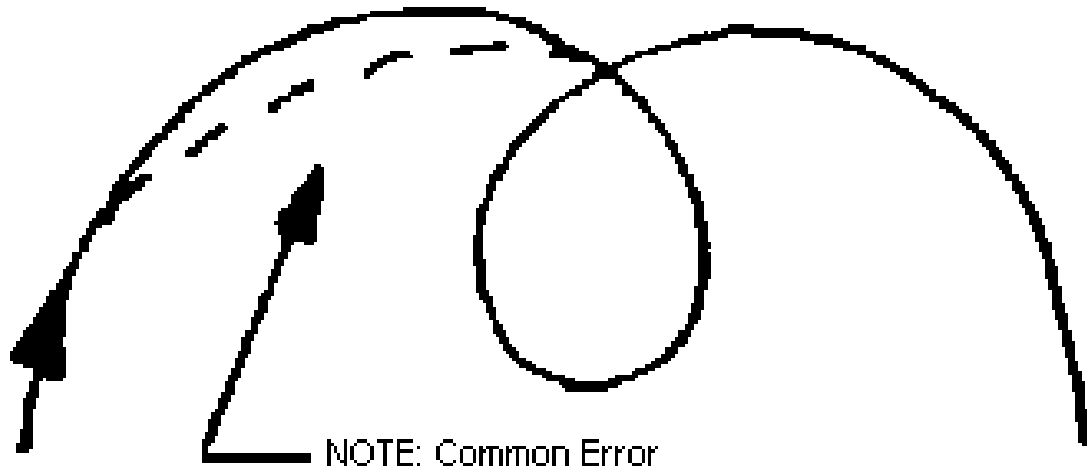

6. Cutting off exit side of Loop.

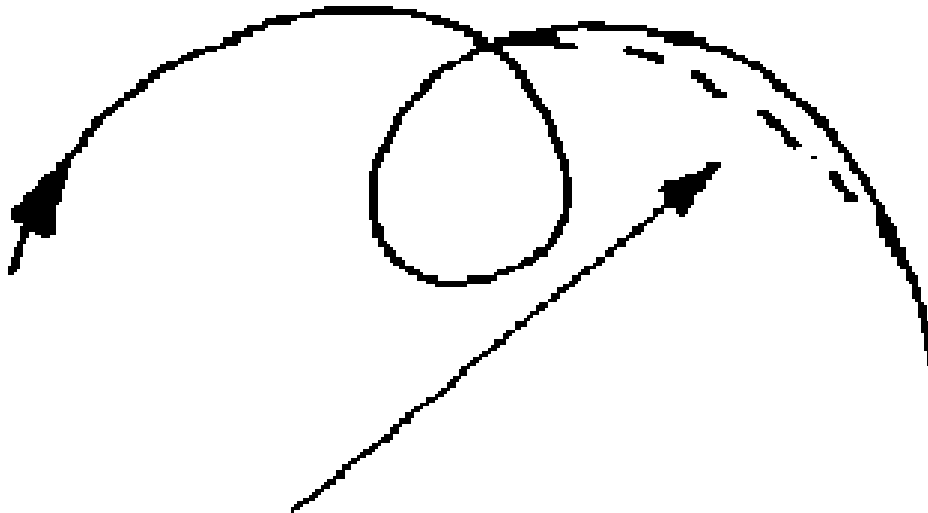

7. Entrance of Loop too full.



8. Exit of Loop too full.

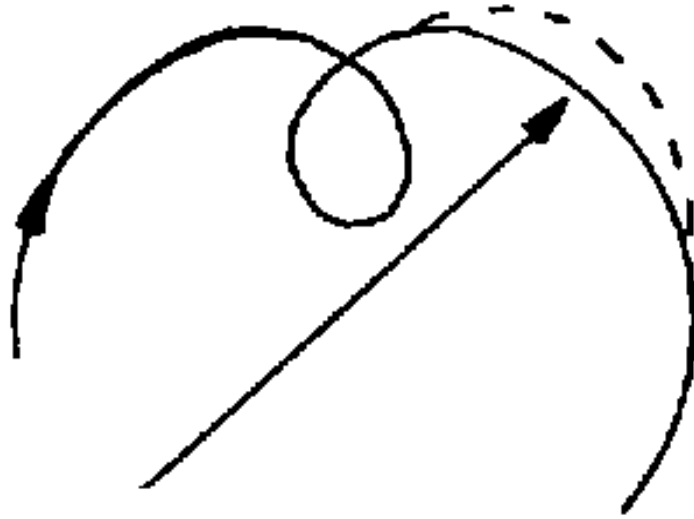

9. One Loop off axis early

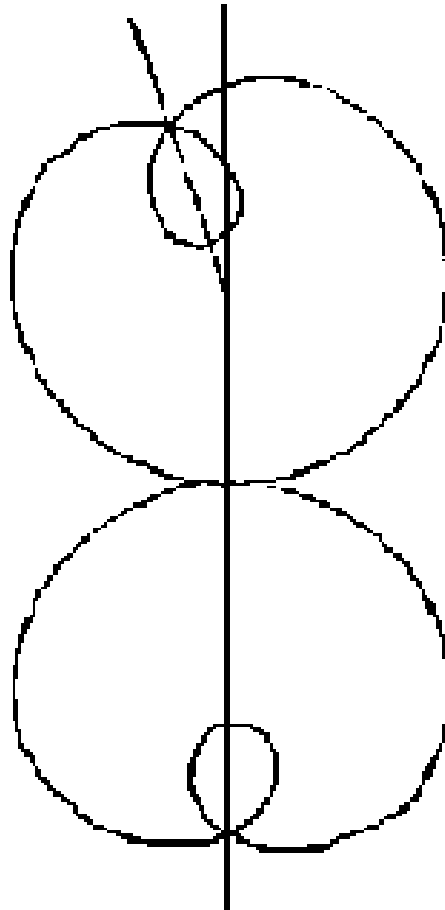

10. One loop off axis late.

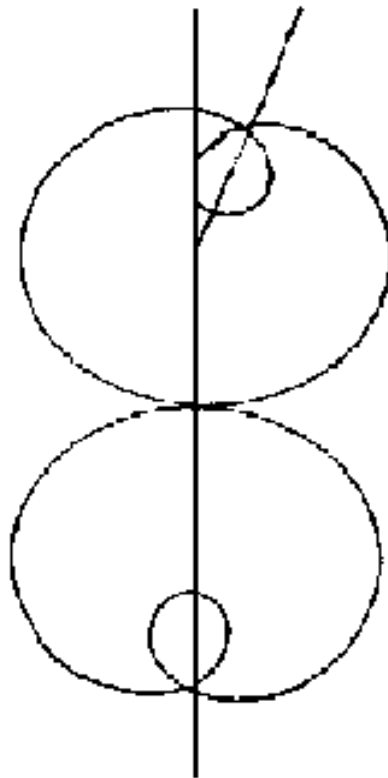

11. Take-offs early; not taken to strike zone.

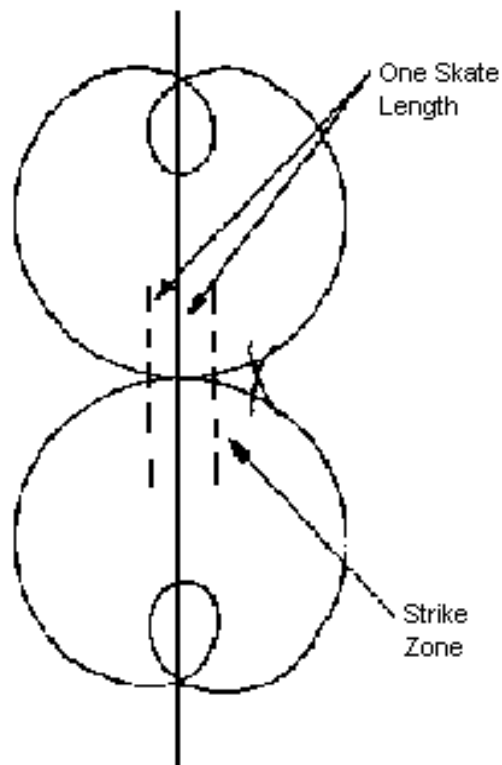

NOTE: Common Error on inside take-offs.

12. Take-offs late; taken past strike zone.

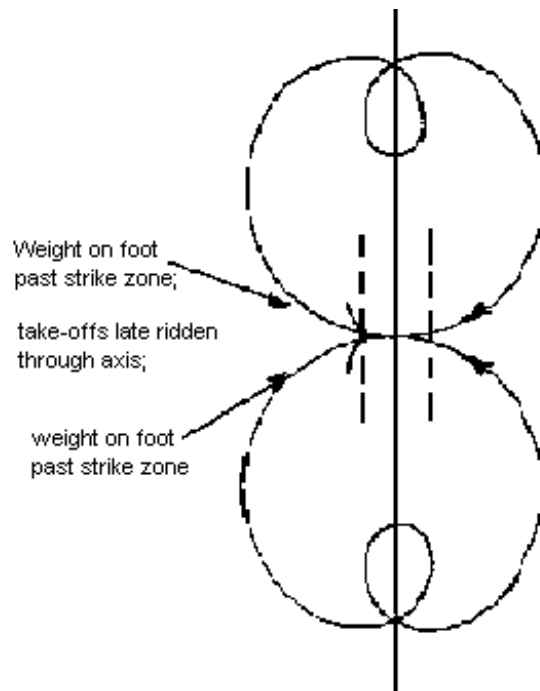

NOTE: Common error on outside take-offs.

13. Pointed Loop.



NOTE: Common error due to stoppage of continuous roll in Loop.

14. Circle Loop; not long enough; too wide for its length.

NOTE: Common error Loop can be rolled around smoothly, so judges must watch closely for proper shape. Loop will be too wide and will not be long enough.



19 Marking for Tests and Competitions

1. Judges shall mark out of ten (10) using one tenth (1/10) decimal points as further intermediate values (Refer CAOC Rule 7.03.01).
2. In assigning a mark, the Judges shall lay equal stress in the first place on correct tracing (to include double and triple repetition) as defined, and carriage and movement as defined under Judging Points on School Figures.
3. Double or triple repetition shall be given credit when the rules of Correct Tracing, Graceful Carriage and Movement are observed.
4. Major faults of figure skating:
 - a. Putting free foot on floor - assigned score to be reduced.
 - b. Falling - assigned score to be reduced.
 - c. Unwarranted rockover or change of edge producing an incorrect turn shall be penalised according to the degree of error.
 - d. Incorrect turn (Three Turn instead of Bracket, Rocker instead of Counter and vice versa) - assigned score to be reduced. It is the responsibility of the Referee to inform the Judges of the fault immediately after the involved skater has finished the figures.
5. Pure edge, even though not on the line, is the most important part of tracing. Tracing, although on the line, at the expense of edge quality (skate wobble) shall be penalised. Momentum of the figure is to be evaluated on its consistency of edge, lean and speed.
6. In all competitive figure event, Judges must consider each of the following applicable points:
 - a. Start
 - b. Tracing
 - c. Turns and/or change of edge
 - d. Second turn
 - e. Placement of turn(s)
 - f. Tracing after/between turns
 - g. Closing circle
 - h. Subsequent take-off
 - i. Concluding figure

Form must be given the required full consideration throughout.

7. In judging competitive Loops, each of the following points must be considered:
 - a. Start
 - b. Tracing
 - c. Loop and/or change of edge
 - d. Tracing after/between Loops
 - e. Closing circle
 - f. Subsequent take-offs
 - g. Concluding figures

Form must be given the required full consideration throughout.